

Operation Manual

Lake[®] LM 26 Digital Audio Loudspeaker Processor



1. Important Safety Instructions

Before using the device, be sure to carefully read the Safety Instructions. Keep this document with the device at all times.

1.1 Important Safety Instructions

1. Read these instructions.
2. Keep these instructions.
3. Heed all warnings.
4. Follow all instructions.
5. Do not use this apparatus near water.
6. Clean only with a dry cloth.
7. Do not block any ventilation openings. Install in accordance with the manufacturer's instructions.
8. Do not install near any heat sources such as radiators, heat registers, stoves, or other apparatus (including amplifiers) that produce heat.
9. Do not defeat the safety purpose of the polarized or grounding-type plug. A polarized plug has two blades with one wider than the other. A grounding-type plug has two blades and a third grounding prong. The wide blade or the third prong is provided for your safety. If the provided plug does not fit into your outlet, consult an electrician for replacement of the obsolete outlet.
10. Protect the power cord from being walked on or pinched, particularly at plugs, convenience receptacles, and the point where they exit from the apparatus.
11. Only use attachments/accessories specified by the manufacturer.
12. Use only with a cart, stand, tripod, bracket, or table specified by the manufacturer, or sold with the apparatus. When a cart is used, use caution when moving the cart/apparatus combination to avoid injury from tip-over.
13. Unplug this apparatus during lightning storms or when unused for long periods of time.
14. Refer all servicing to qualified service personnel. Servicing is required when the apparatus has been damaged in any way, such as power-supply cord or plug is damaged, liquid has been spilled or objects have fallen into the apparatus, the apparatus has been exposed to rain or moisture, does not operate normally, or has been dropped.
15. Use the mains plug to disconnect the apparatus from the mains.
16. **WARNING:** To reduce the risk of fire of electric shock, do not expose this apparatus to rain or moisture.
17. Do not expose this equipment to dripping or splashing and ensure that no objects filled with liquids, such as vases, are placed on the equipment.
18. The mains plug of the power supply cord shall remain readily operable.
19. Do not connect the unit's output to any other voltage source, such as battery, mains source, or power supply, regardless of whether the unit is turned on or off.
20. Do not remove the top (or bottom) cover. Removal of the cover will expose hazardous voltages. There are no user serviceable parts inside and removal may void the warranty.
21. An experienced user shall always supervise this professional audio equipment, especially if inexperienced adults or minors are using the equipment.
22. The US National Differences clause 16.3 requires that network cables must be flame rated VW-1.



To prevent electric shock do not remove top or bottom covers. No user serviceable parts inside, refer servicing to qualified service personnel.



À prévenir le choc électrique n'enlevez pas les couvercles. Il n'y a pas des parties serviceable à l'intérieur, tous reparations doit être faire par personnel qualifié seulement.



To completely disconnect this equipment from the AC mains, disconnect the power supply cord plug from the AC receptacle. The mains plug of the power supply cord shall remain readily operable.



Pour démonter complètement l'équipement de l'alimentation générale, démonter le câble d'alimentation de son réceptacle. La prise d'alimentation restera aisément fonctionnelle.



1.2 Standards



This equipment conforms to the requirements of the EMC Directive 2004/108/EC and the requirements of the Low Voltage Directive 2006/95/EC.

Standards applied: EMC Emission EN55103-1, E3
EMC Immunity EN55103-2, E3, with S/N below 1% at normal operation level.
Electrical Safety EN60065, Class I



This equipment is tested and listed according to the U.S. safety standard ANSI/UL 60065 and Canadian safety standard CSA C22.2 NO. 60065. Intertek made the tests and they are a Nationally Recognized Testing Laboratory (NRTL).

1.3 Explanation of Graphical Symbols



The lightning bolt triangle is used to alert the user to the presence of un-insulated "dangerous voltages" within the unit's chassis that may be of sufficient magnitude to constitute a risk of electric shock to humans.



The exclamation point triangle is used to alert the user to presence of important operating and service instructions in the literature accompanying the product.

1.4 WARNING



To reduce risk of fire or electric shock, do not expose this apparatus to rain or moisture.
Pour réduire les risques de blessure ou le choc électrique, n'exposez pas l'appareil à la pluie ou à l'humidité.

Do not expose this system/apparatus to dripping or splashing and ensure that no objects filled with liquids, such as vases, are placed on the apparatus.

L'appareil ne doit pas être exposé à des égouttements d'eau ou des éclaboussures et de plus qu'aucun objet rempli de liquide tel que des vases ne doit pas être placé sur l'appareil.

This apparatus must be connected to a mains socket outlet with a protective earthing connection.
Cet appareil doit être raccordé à une prise de courant qui est branchée à la terre.

The mains plug is used as a disconnect device and shall remain readily operable.

Lorsque la prise du réseau d'alimentation est utilisée comme dispositif de déconnexion, ce dispositif doit demeurer aisément accessible.

1.5 CAUTION



To reduce the risk of fire or electric shock, do not remove screws. No user-serviceable parts inside.
Refer servicing to qualified service personnel.

Pour réduire le risque d'incendie ou de choc électrique, ne pas retirer les vis. Aucune pièce réparable par l'utilisateur. Confier l'entretien à personnel qualifié.

1.6 FCC Compliance Notice (Radio Interference)

A sample of this product has been tested and complies with the limits for the European Electro Magnetic Compatibility (EMC) directive. This equipment has also been tested and found to comply with the limits for a Class B digital device, pursuant to Part 15 of the FCC Rules. These limits are designed to provide reasonable protection against harmful interference from electrical equipment. This product uses radio frequency energy and if not used or installed in accordance with these operating instructions, may cause interference to other equipment, such as radio receivers.

However, there is no guarantee that interference will not occur in a particular installation. If this equipment does cause harmful interference to radio or television reception, which can be determined by turning the equipment on and off, the user is encouraged to try to correct the interference by one or more of the following measures:

- ▶ Reorient or relocate the antenna.
- ▶ Increase the separation between the equipment and receiver.
- ▶ Connect the equipment to an outlet on a circuit different from that to which the receiver is connected.

- ▶ Check if the affected unit complies with the EMC limits for immunity, (CE-labeled). If not, address the problem with the manufacturer or supplier. All electrical products sold in the EC must be approved for immunity against electromagnetic fields, high voltage flashes, and radio interference.
- ▶ Consult the dealer or an experienced radio/TV technician for help.

1.7 User Responsibility

1.7.1 Mains Connection Grounding



Your apparatus must be connected to a grounded socket outlet.

1.7.2 Maintenance

For safe and reliable operation, the dust filter on the right-hand side air intake should be removed and cleaned regularly to ensure maximum airflow through the device.



If the dust filter is not maintained there will be safety risks; for example, high internal temperatures could ignite the dust start a fire. There is also a risk that the unit will malfunction since it is dependent on constant airflow from left to right. If the dust filter is not clean and the unit malfunctions, any resulting problems will not be covered by the warranty.

Table of Contents

| | |
|---|-----------|
| 1. Important Safety Instructions | i |
| 1.1 Important Safety Instructions | i |
| 1.2 Standards | i |
| 1.3 Explanation of Graphical Symbols | i |
| 1.4 WARNING | ii |
| 1.5 CAUTION | ii |
| 1.6 FCC Compliance Notice (Radio Interference)..... | ii |
| 1.7 User Responsibility | iii |
| 2. Welcome | 1 |
| 2.1 Introduction | 1 |
| 2.2 Main Features | 1 |
| 2.3 Additional Documentation..... | 2 |
| 3. Installation..... | 3 |
| 3.1 Unpacking | 3 |
| 3.2 Mounting..... | 3 |
| 3.3 Cooling | 3 |
| 3.4 Operating Voltage | 4 |
| 3.5 Grounding..... | 4 |
| 4. Product Overview | 5 |
| 4.1 Front Panel Overview..... | 5 |
| 4.2 Back Panel Overview | 7 |
| 5. Signal Flow and Lake Processing | 10 |
| 5.1 Signal Flow | 10 |
| 5.2 Lake Processing and Control..... | 11 |
| 5.3 Modules and Frames | 11 |
| 5.4 Loudspeaker Crossover Configuration Overview..... | 12 |
| 5.5 Files and Presets..... | 12 |
| 6. Front Panel Interface | 14 |
| 6.1 Overview..... | 14 |
| 6.2 Front Panel Key Lock..... | 15 |
| 6.3 Power Button | 15 |
| 6.4 Meter Button | 15 |
| 6.5 Menu Button | 16 |
| 6.6 Exit Button | 16 |
| 6.7 Dynamic Buttons, Controls and LEDs..... | 16 |
| 6.8 Module I/O Mute Buttons and LED Meters..... | 19 |
| 6.9 Meter Mode | 20 |
| 6.10 Menu Mode | 21 |

| | |
|---|-----------|
| 7. Back Panel Interface | 38 |
| 7.1 Analog Inputs and Outputs | 38 |
| 7.2 AES3 Digital I/O | 40 |
| 7.3 RJ45 etherCON® Network Connections | 42 |
| 7.4 GPIO Connection | 43 |
| 7.5 Universal Power Supply Connection | 44 |
| 8. Appendix | 45 |
| 8.1 Faults and Warnings Overview | 45 |
| 8.2 Maintenance | 46 |
| 8.3 Factory Default Settings..... | 46 |
| 8.4 Glossary of Terms, Acronyms and Abbreviations | 47 |
| 9. Application Guide | 50 |
| 9.1 Gain Structure | 50 |
| 9.2 Gain / Level Optimization | 51 |
| 9.3 Digital Audio Connections | 51 |
| 9.4 Digital Clock Configuration..... | 53 |
| 10. Technical Specifications | 56 |
| 11. Warranty and Support | 57 |
| 11.1 General | 57 |
| 11.2 International Warranties | 57 |
| 11.3 Technical Assistance and Service | 57 |
| 11.4 Trademarks..... | 58 |

2. Welcome

2.1 Introduction

Thank you for choosing the Lake LM 26. We are confident that you will be pleased with the performance, unique features, configuration flexibility, reliability, and long-term durability offered by this product.

For fast installation and use of this product, your welcome package includes a printed copy of the LM 26 Quick Start and Field Reference Guide which contains the information required to safely install the product and place it in service. Control and editing features are accessible via the front panel interface or via the included Lake Controller software.

It is recommend that the Quick Start Guide and all product documentation on the included CD-ROM is reviewed to ensure familiarity with the various configuration and control options.

Thank you again for placing your confidence in Lake products.

2.2 Main Features

The Lake LM 26 incorporates a number of sophisticated technologies to ensure the best possible performance and many years of reliable operation. The following section summarizes the benefits of each feature; additional information is available in the reference manuals.

2.2.1 Lake Processing and Controller

The Lake LM 26 integrates seamlessly into the Lake Processing environment. Two processing modules offer precise settings for gain, delay, crossover settings, equalization and limiting. Lake processing features incorporated in each module include Raised Cosine Equalization™, linear phase crossovers, and LimiterMax™ loudspeaker protection. The Super Module feature allows hardware processing modules in two or more separate devices to function as a single module in the Lake Controller software. Please refer to the Lake Controller Operation Manual for further information.

2.2.2 Lake Analyzer Bridge

Lake Controller software provides integration with third-party real-time analyzers, providing simultaneous measurement display and EQ adjustment via the Lake Controller.

The third-party measurement tools that can be integrated via the Analyzer Bridge include:

- ▶ Smart Live Version 5.4
- ▶ Live-Capture Light / Live-Capture Pro

Smaart, distributed and supported by Rational Acoustics, provides real-time sound system measurement, optimization and control. Smaart combines several powerful audio frequency measurement and analysis tools.

Live-Capture, created by WaveCapture, offers easy-to-use software and measurement tools for sound engineers, installers, consultants and designers. The Lake Analyzer Bridge in conjunction with Live-Capture Light provides a completely free spectrum analyzer via your Lake Controller software interface.

2.2.3 Dante™ Audio Network

The Lake LM 26 includes Dante digital audio networking as standard. Utilizing the latest advances in Ethernet technology, Dante offers simplified system configuration and extremely low latency while delivering very high quality uncompressed digital audio across the Lake network. The Zen™ automatic configuration feature enables plug-and-play setup without third-party DHCP or DNS servers. Dante is compatible with high-bandwidth networks, allowing large numbers of audio channels to be distributed alongside control and analyzer data.

2.3 Additional Documentation

This document, the Lake LM 26 Operation Manual, serves as the primary reference source for detailed information on the installation and operation of the Lake LM 26. It also provides detailed information on set-up and configuration using the front-panel interface.

If you intend to use the device as part of a networked system, or access features via the Lake Controller, please refer to the various supporting documents which can be located via these methods:

- ▶ Start > Programs > Lake Controller > Documentation (after installing Lake Controller software)
- ▶ On the Installer CD-ROM or the downloaded software installer
- ▶ Online at: <http://labgruppen.com/index.php/products/documentation/>

3. Installation

3.1 Unpacking

Carefully open the shipping carton and check for any damage to the device or the supplied accessories. Every Lake product is tested and inspected before leaving the factory and should arrive in perfect condition. If any damage is discovered, please notify the shipping company immediately. Only the consignee may initiate a claim with the carrier or their insurers for damage incurred during shipping. Save the carton and packing materials for the carrier's inspection.

In addition to the Lake LM 26, the shipping carton include the following items:

- ▶ Lake LM 26 Quick Start and Field Reference Guide
- ▶ AC mains lead (IEC power cable) with locking connector
- ▶ AES break-out cable (4-in, 8-out)
- ▶ Software Installer and Documentation CD-ROM

Please keep the original carton and associated packaging to facilitate shipping of the device should the need arise.

3.2 Mounting

Airflow for cooling the LM 26 is from side to side (right-side intake to left-side fan). Please ensure there is sufficient space each side of the unit to allow airflow; the space provided by standard rack-rails should be sufficient. This device has no top or bottom vents and therefore may be stacked directly on top of each other.

Sufficient space should be available at the front of the rack to accommodate the handles, and at the rear to accommodate connectors and cables; allowance must be made for cable or loom bends within a rack.

3.3 Cooling

The Lake LM 26 uses a forced-air cooling system, with airflow from right to left. The dust filter on the air intake (right-side) should be regularly cleaned, especially after exposure to dusty environments, to ensure the maximum possible airflow through the unit.

The LM 26 is designed to operate in situations where the ambient temperature is below 55 °C (131 °F). Automatic actions and warnings occur at following temperature thresholds:

- ▶ At 40 °C (104 °F) or less, the fan is OFF
- ▶ At more than 40 °C (104 °F) the fan is ON

- ▶ At 55 °C (131 °F) a temperature warning is indicated on the front panel as 'TEMP WARNING' and in the Controller Event Log as 'Temp warning: DSP area'.
- ▶ At 70 °C (158 °F) the LM 26 has exceeded the maximum normal operating temperature. This fault is indicated on the front panel as 'OVERTEMP' and in the Controller Event Log as 'Temp fault: DSP area'.



The Processor will NOT mute or shut down when the temperature reaches or exceeds 70 °C (158 °F), however, sustained performance at this temperature cannot be guaranteed.

3.4 Operating Voltage

The label above the GPIO connector, and to the left of the mains (AC) connector indicates the AC mains voltage range for which the LM 26 is approved.

The LM 26 utilizes a universal power supply, and will operate within the range 70-265V~50-60Hz : 30W. If the plug on the IEC cable provided is not appropriate for your country, a locally-sourced IEC cable with the appropriate molded plug should be used.

Once a suitable AC power supply is connected, the device can be turned on using the front panel power button. When turned on, a diagnostic routine is performed and the power button LED changes from red (Standby) to green (Active).

3.5 Grounding

Analog inputs and outputs feature Iso-Float™ ground isolation, a technology which combines the benefits of transformer-coupled isolation with the advantages of clean, direct-coupled inputs and outputs.

The audio converters are galvanically isolated, and not connected to the main ground. High-speed transformers and opto-isolators create a barrier between the device and the outside electrical environment.



The Iso-Float feature is activated by default, but may be disabled via the Lake Controller software, or via the front panel menu.

Use correctly-shielded balanced audio input connections to minimise hum and interference. Please refer to section 7.1.5 for further information.



NEVER disconnect the earth (ground) pin on the mains cable (AC power cord).

4. Product Overview

This chapter provides an overview of key features and functionality. For further information please see chapters 5 to 9 of this Operation Manual.

4.1 Front Panel Overview

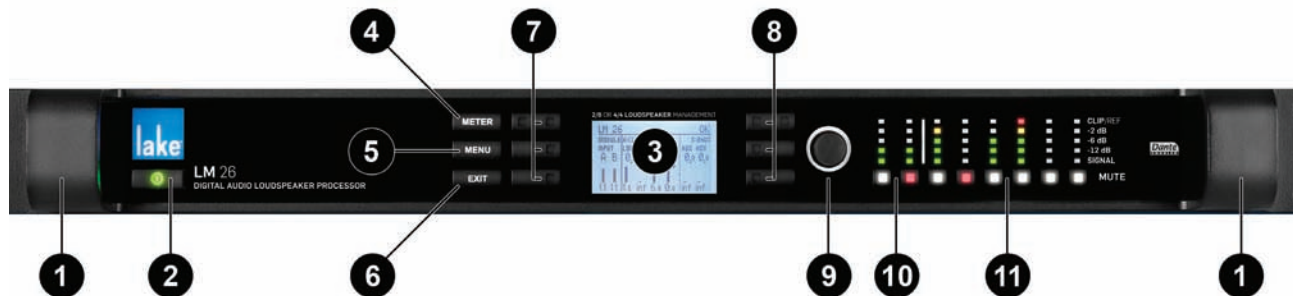

Figure 4-1: LM 26 Front Panel Overview

The front panel controls are clustered around a daylight readable LCD **3**, allowing adjustment and monitoring of the majority parameters and meters. The two clusters of controls on either side of the LCD include three dedicated function buttons **4** **5** **6**, six dynamic function buttons with embedded LEDs **7** **8** and a rotary data encoder **9**. To the right of these controls are dedicated module input **10** and output **11** mute buttons and level meters.

1 Handles

Two sturdy metal handles are fitted to the front panel. The handles should be used when carrying the device, and when fitting it in or removing it from a rack. Ensure that any door or removable rack front cover has sufficient depth to clear the handles.

2 Standby

The LM 26 is powered on and to standby using the left-most button, or via the Lake Controller.



All audio in and out of the processor is muted when in Standby mode. Network communication remains active to allow the LM 26 to be turned on via the Lake Controller.

③ Display

The display illuminates when the device is on. The LCD, function buttons, and the rotary encoder provide real-time control and monitoring of most parameters. The LEDs embedded in the function buttons indicate available menu options, provide confirmation of Controller communication, and indicate various faults and warnings.

The brightness and contrast of the display and front panel LEDs can be adjusted via the front panel menu.

Please refer to chapter 6 for further details.

④ Meter

The METER button toggles between two alternative meter views: Home View and I/O Status. Pressing METER from Menu Mode returns the screen to Meter Mode with Home View displayed. Please refer to section 6.4 for further details.

⑤ Menu

After pressing the MENU button, the LCD will display the top level menu. In Menu Mode the function buttons enable access to various information and functions. Please refer to section 6.5 for further details.

⑥ Exit

The EXIT button is used primarily while navigating the menu system in Menu Mode; pressing EXIT will return the menu up one level. In Meter Mode, pressing EXIT returns the metering display to the default Home View.

⑦ Dynamic Function Buttons with LEDs (Left of LCD)

The function of these buttons change according to the currently selected view or menu.

The left LED in the top button illuminates white to indicate the Frame is selected in the Lake Controller, or flashes white to indicate communication from the Lake Controller. If this button is pressed while in Home View, and with the Lake Controller on the Home page or the Modules Menu, then Module A of the selected frame will be highlighted in the Controller.

The three LEDs on the right side of each button illuminate white when an associated option is available on the LCD screen.

Please refer to chapter 6 for further details.

8 Dynamic Function Buttons with LEDs (Right of LCD)

The function of these buttons change according to the currently selected view or menu.

The right bi-color LED in the top button illuminates red or yellow to indicate faults or warnings. If this button is pressed while in Home View, and with the Lake Controller on the Home page or the Modules Menu, then Module B of the selected frame will be highlighted in the Controller.

The three LEDs on the left side of each button illuminate white when an associated option is available on the LCD screen.

Please refer to chapter 6 for further details.

9 Rotary Encoder

The rotary encoder is used to modify various parameters (e.g. input level) via the menu. When a menu item is selected that permits adjustment of parameter values, the ring around the rotary encoder illuminates. In Home View the encoder can be used to scroll through the Meter Views.

10 Input Mutes and Meters

Independent mute buttons and five-segment LED meters are provided for the inputs to Module A & B. The associated meters provide signal, pre-clip and clip conditions. The embedded LEDs confirm if the Module input is muted (red), unmuted (white), or unused (not illuminated). The button can be used to mute/unmute the inputs as required. Please refer to section 6.7 for further information.

11 Dedicated Output Mute Buttons and LED Meters

Independent mute buttons and five-segment LED meters are provided for Outputs 1 > 6. The embedded LEDs confirm if the Module output is muted (red), unmuted (white), or unused (not illuminated). The bottom three segments (green) indicate signal; the 4th segment (yellow) indicates signal 2 dB below clipping; the 5th segment (red) indicates signal clipping. Please refer to section 6.7 for further information.

4.2 Back Panel Overview

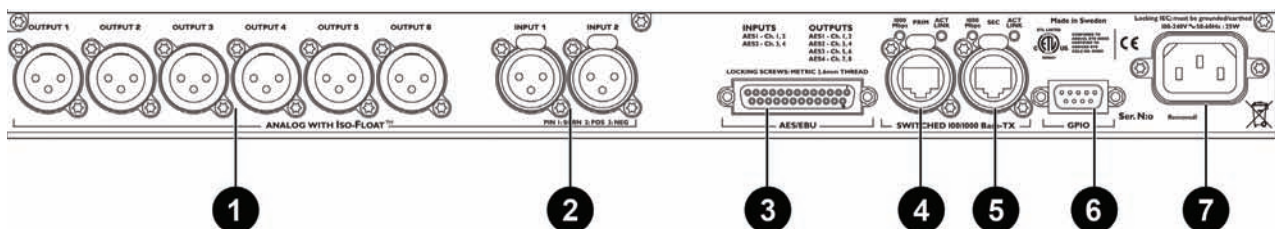

Figure 4-2: LM 26 Back Panel Layout

① Analog Outputs

Six analog outputs are provided via standard XLR3M connections. The outputs are electronically balanced and feature Lake Iso-Float circuitry. The output impedance is 50 ohms, providing a maximum output level of +21 dBu. Please refer to section 7.1 for further information.

② Analog Inputs

Two analog inputs are provided via standard XLR3F latching connectors. The inputs are electronically balanced and feature Lake Iso-Float circuitry. The impedance is 20 kOhms (balanced), and the inputs can accept a maximum input level of +26 dBu. Please refer to section 7.1 for further information.

③ AES3 I/O

AES inputs and outputs are provided via a 25-pin DB25 connector. Inputs can be received on AES1 (Ch.1,2) and AES2 (Ch.3,4). Outputs are via AES1 (Ch.1,2), AES2 (Ch.3,4), AES3 (Ch.5,6) and AES4 (Ch.7,8). Please refer to section 7.2 for further information.

The sample rates available for AES3 inputs and outputs are 44.1, 48, 88.2, 96, 176.4, 192 kHz.

④ Primary Network Connector

The primary Neutrik RJ45 etherCON® connection provides integration into an Ethernet control network which may include other Lake Processors and the Lake Controller software. Network connection permits full control of all functions along with real-time metering from a remote position. This device supports the Dante audio networking protocol, which allows transmission of multichannel, high-definition digital audio over the same Ethernet connection.

Use the primary connector when using a star network topology, consisting of individual Cat-5e connections between the devices and an Ethernet switch. Alternatively this connection can be used to daisy chain directly to another Lake Processor. The daisy chain topology should not be used with Dante.

For a technical reference of the Ethernet Port, please refer to section 7.3. Additional information is available in the Lake Network Configuration Guide.



The Ethernet ports automatically switch to operate at Ethernet data rates of 100 Mbps or 1000 Mbps, and allow straight or crossed network cables. Two LEDs above each port indicate valid network connection (LINK) and network activity (ACT).

5 Secondary Connector

The secondary network connector can be used to daisy-chain multiple PLM Series, LM 26 and legacy Lake devices. Alternatively, a dual-network topology can be created by connecting all secondary network connectors to a separate Ethernet switch, ensuring full redundancy in the event of a network component failure.



Additional processor configuration is required for a dual redundant network setup. See the Lake Controller Operation Manual for further details.

For a technical reference of the Ethernet Port, please refer to section 7.3. Additional information is available in the Lake Network Configuration Guide.



When connecting multiple devices to an Ethernet network, care must be taken NOT to create a closed loop which causes network malfunction.

6 GPIO Connector

A 9-pin GPIO (General Purpose Input Output) connection is provided to enable integration with external systems such as alarm/fire systems, providing basic control of power state, mute along with fault notification to an external monitoring system. Please refer to sections 6.10.4.4 and 7.4 for further details.

7 Mains Power Connector

A universal power supply capable of accepting 70-265 V ~ 50-60 Hz : 30 W is built into the LM 26. The IEC power cable provided includes a locking feature via a pin on the bottom of the connector; the connector can accept standard or locking IEC power cables.

The power supply must be connected to AC mains using a power cable with a correctly wired plug for the country of operation.

5. Signal Flow and Lake Processing

5.1 Signal Flow

Figure 5-1 depicts the audio signal flow inside an LM 26. It is worth noting that this sophisticated device provides five points in the signal chain where the signal level can be adjusted, muted or disconnected.

Important information regarding correct setting of the gain structure can be found in section 9.1.

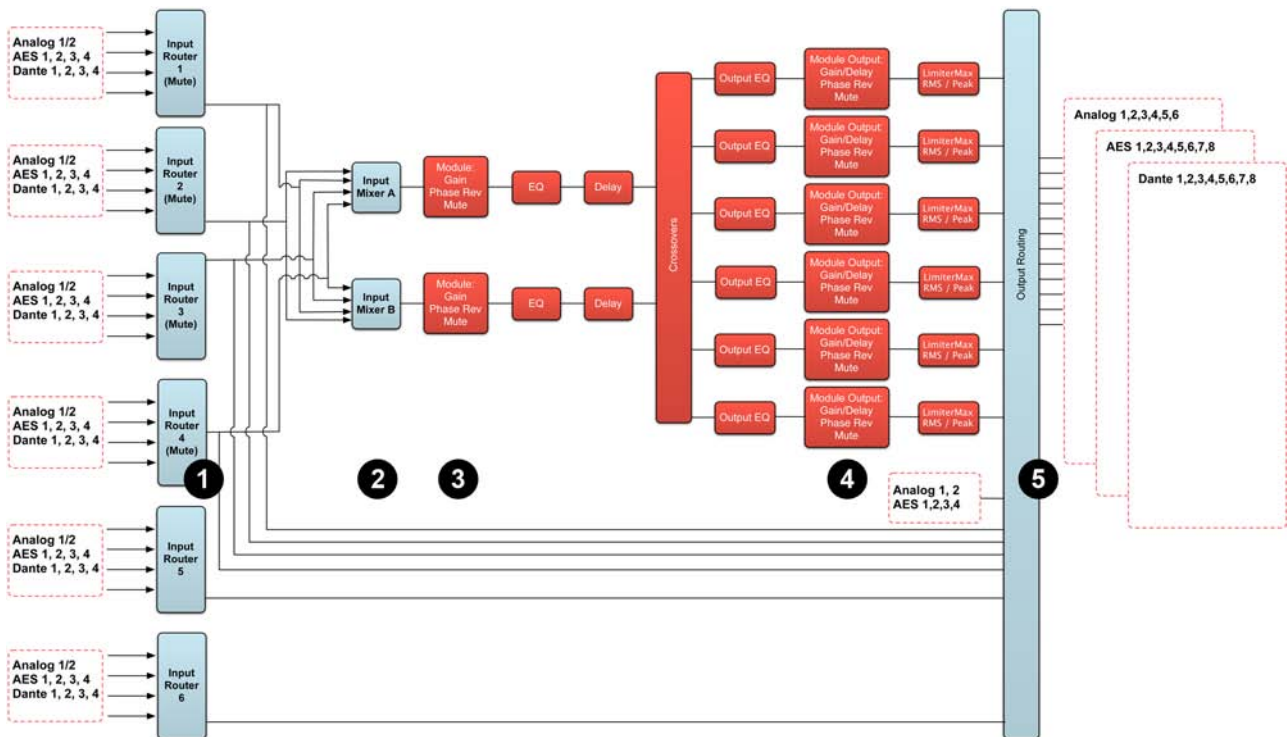

Figure 5-1: Signal Flow Diagram (LM 26)

5.1.1 Level Adjustments & Mute Points

- ① Input Router Stage - Input selection and MUTE
- ② Input Mixer Stage - Router ON/OFF connection to mixer and gain settings
- ③ Module Input Stage - Mute and gain settings
- ④ Module Output Stage - Mute and gain settings
- ⑤ Output Router Stage - Output ON/OFF routing connections

Input routers 1-4 provide all five stages of functionality via the front panel interface or the Lake Controller. The pass-thru input routers 5&6 allow stage 1 input selection only (MUTE is unavailable), along with stage 5 output ON/OFF routing connections.



If the required audio signal is not passing correctly, verify the connection, mute and volume settings at all five stages.

5.2 Lake Processing and Control

As outlined in section 2.2.1, this device integrates seamlessly into the Lake Processing environment, providing all features, functionality and connectivity associated with all Lake Processors. The internal Lake Processing includes programmable crossovers, EQ, dynamics and other functions, and can be fully controlled via the supplied Lake Controller software. Additionally, many functions can be controlled or accessed directly via the front panel.

The Lake Controller Operation Manual and Lake Network Configuration Guide are supplied on the accompanying CD ROM and additional documentation is available from the Start Menu after software installation.

5.3 Modules and Frames

5.3.1 Overview

A Frame represents one physical Lake Processor (e.g. a PLM or LM 26). A maximum of two Modules are contained within each Frame; these are referred to as Module A and Module B. The number of Modules shown in a given Frame is dependent upon the signal processing configuration of that Frame.

Each Module can be configured as a Classic Crossover (Bessel, Butterworth, Linkwitz-Riley), as a Linear Phase Crossover, or as multiple full bandwidth Auxiliary Outputs. The default configuration for the LM 26 is 2 x Classic 3-Way Modules, providing a total of six module outputs.

Please refer to the Lake Controller Operation Manual for further information.

5.3.2 Super Modules

Super Modules allow control of multiple Modules of the same type, distributed across multiple Frames, as a single entity within the Lake Controller software. A change made in the Super Module is replicated across all assigned Modules, resulting in improved efficiency in system configuration and a reduction of on-screen icons within the Lake Controller software.

The key benefit of this feature is the ability to connect and control crossovers, levels and EQ across multiple hardware devices simultaneously from the Lake Controller. For example, one device may be driving sub and low-frequency speakers, while another device controls mid-range and hi-frequency drivers. Using a single adjustment the crossover points between the two devices can be changed simultaneously.

Please refer to the Lake Controller Operation Manual for further information regarding Super Modules.

5.4 Loudspeaker Crossover Configuration Overview

The Lake Processing system within LM 26 devices may be configured with up to two inputs and up to six Module outputs. Each set of processing elements is referred to as a Module and can be configured as crossovers, full-bandwidth auxiliary outputs, or a combination of the two. The relationship between inputs and outputs is defined via the Lake Controller or via the front panel I/O CONFIG Menu.

The Lake Processing system provides two distinct categories of crossovers:

- ▶ Infinite Impulse Response filters (IIR) such as the classic Bessel, Butterworth or Linkwitz-Riley types; these are available with slopes ranging from 6 dB/octave to 48 dB/octave.
- ▶ Finite Impulse Response filters (FIR) providing zero phase shift with steep transition slopes at the crossover frequencies. These are also referred to as Linear Phase Crossovers.

Further details on these types of crossovers and information on configuring various module types can be found in the Lake Controller Operation Manual.

5.5 Files and Presets

The Lake system provides various methods for storing and recalling Module, Frame, or system-wide data. A overview is provided below; for further information please refer to the Lake Controller Operation Manual.

5.5.1 Module, System and Sub-System Configuration Files

Module, System and Sub-System Configuration files are stored on the Lake Controller PC, and data is passed across the network when recalling or storing these type of files.

- ▶ A Module file is the smallest set of data that can be stored and recalled; it contains crossover, gain, delay, and limiter information for an individual loudspeaker. A Module file may be recalled into other Lake devices. It is not possible to store a Module File directly on the hardware device.
- ▶ A System or Sub-System Configuration File contains a set of Module file information in addition to Frame related information such as I/O routing, along with Group control information.

5.5.2 Frame and System Presets

This device allows the complete processor configuration to be stored as a Frame Preset on the hardware unit itself. Presets can be recalled via the front panel (please refer section 6.10.6) to or via the Lake Controller software (please refer to the Lake Controller Operation Manual).

A maximum of 100 Frame Presets can be stored on this device. The data within a Frame Preset includes the configurations of both Modules in the Frame, including all levels, crossover, EQ, input mixer, output routing, and all other Module, Frame and Group parameters. As Frame Presets are stored in the device, complete processor configurations may be recalled without the need to connect the device to a PC.

Using the System Presets function in the Lake Controller, entire system configurations can be stored and recalled across a network of LM 26, PLM, Mesa Quad EQ, Contour Pro 26, and Dolby Lake Processors. This enables fast retrieval and switching of entire system configurations as minimal data is being sent between the Controller and Processors.

6. Front Panel Interface

An overview of the front panel interface is provided in section 4.1. This chapter describes each cluster of controls as shown in Figure 6-1.



Figure 6-1: Front Panel Interface

6.1 Overview

The majority of LM 26 functions can be controlled and monitored via LCD display screen ③, function buttons ④ ⑤ ⑥ ⑦ ⑧, rotary encoder ⑨ and the dedicated Module input ⑩ and Module output ⑪ mute buttons and metering LEDs.

The front panel has two basic modes: Meter Mode and Menu Mode.

- ▶ Meter Mode provides two views: Home View (default). To toggle these views, press the METER button. Please refer to section 6.9 for further information on Meter Mode.
- ▶ Menu Mode provides various menus for viewing and editing parameters and is selected by pressing the MENU button. Select the required submenu by pressing the associated button. Please refer to section 6.10 for further information on Menu Mode.

6.1.1 Warning, Fault and Mute Indications

Fault or warning conditions are indicated via the tricolor LEDs embedded in the dynamic function buttons; a simultaneous description is shown adjacent to the button, on the LCD.

A full list, description and priority of the fault and warning indications is provided in section .

6.1.2 Highlighting a Module in the Lake Controller software via the LM 26

It is sometimes useful to identify which Module icon/s in the Lake Controller software are associated with a particular hardware Frame. To highlight the module in the Lake Controller software:

1. Ensure Meter Mode is selected
2. Press the button adjacent to the Module description on the LCD

If the Frame is online, but the Module is not in the work area, the selected Module will be centred on the Module scroll bar (assuming the Modules Menu is selected in the Lake Controller).

6.2 Front Panel Key Lock

It is possible to lock the front panel buttons for security purposes. When this function is active, all front panel controls are disabled and all adjustment must be made via the network. To lock controls, press and hold button **A** then simultaneously press button **B** as shown in Figure 6-2; repeat this process to unlock.

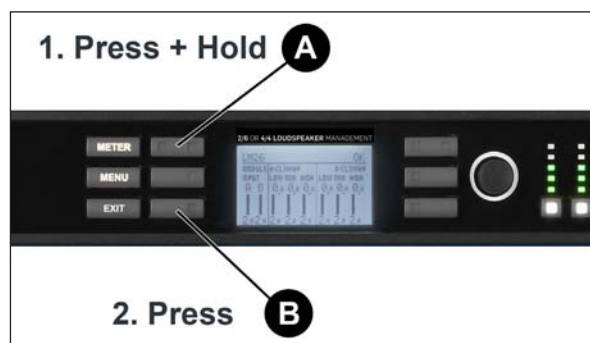

Figure 6-2: Locking / Unlocking Front Panel Controls

6.3 Power Button

The unit is powered on by pressing the left-most button on the front panel, labelled **2** in Figure 6-1. It has a bi-color power symbol which illuminates red when connected to the AC mains and the unit is in standby mode. It turns green when the button is pressed to turn the processor on. A subsequent press of this button returns the unit to standby mode.

6.4 Meter Button

The front panel display has two main operating modes, Meter Mode (default) and Menu Mode. In normal operation, the display will be in Meter Mode.

There are two views available in Meter Mode: Home View (default) and I/O Status View. Pressing the METER button **4** toggles between these views. Pressing the METER button when in Menu Mode will return the system to Meter Mode, with the Home View displayed. Please refer to section 6.9 for further information.

6.5 Menu Button

Menu Mode is selected by pressing the MENU button **5**. The screen displays the top level menu with various submenu options. Press the button adjacent to the required submenu to select it.

Pressing the MENU button while in Menu Mode will display the previous menu level.

Menu Mode is used for processor configuration, or for editing a parameter. Please refer to section 6.10 for further details.

6.6 Exit Button

In Menu Mode, pressing the EXIT button **6** returns back one menu level. In Meter Mode, pressing EXIT returns the display to the Home View.

6.7 Dynamic Buttons, Controls and LEDs

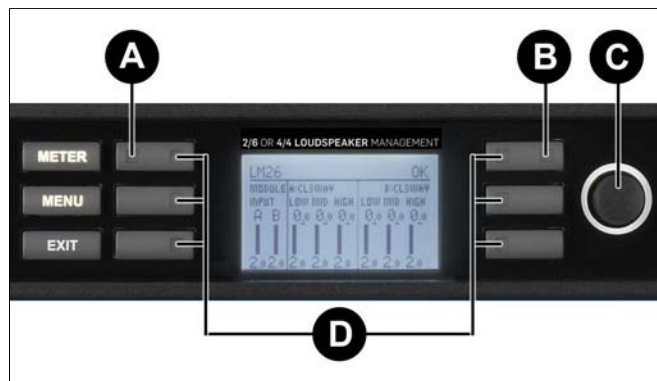

Figure 6-3: LCD with Dynamic Buttons, Controls and LEDs

6.7.1 Communication LED **A**

This bright white LED signifies selection in the Lake Controller, or Controller communication providing visual confirmation of:

1. Network communication between the Lake Controller and the Lake Processor (Flashing LED).
2. Selection of the Lake Processor in the Lake Controller software (Steady LED).



The Communication LED can be dimmed via the front panel by selecting Frame menu, and then Front - Dimming.

6.7.2 Faults and Warnings LED **B**

This bi-color LED turns red to indicate a fault or mute state and turns yellow to indicate a warning. Additional clarification of the fault or warning is displayed in the LCD. Table 6-1 describes the fault and mute states displayed of the front panel, which are signified by a red LED. Table 6-2 describes the front panel warnings which are signified by a yellow LED.

Additional faults and warnings are reported in the Event Log of the Lake Controller only. Section 8.1 lists all faults and warnings recorded in the Event Log and describes the scenarios that may have arisen to cause them.

| Fault / Mute Description | LCD Warning Text | Event Log Warning Text |
|---------------------------|------------------|---------------------------|
| Protective Mute State | PROTECTIVE MUTE | Protective mute via GPIO |
| Overtemperature | OVERTEMP | Temp Fault: DSP area |
| No Input Source Available | NO INPUT | No Input Source |
| Analog Input Fault | ANALOG IN FAULT | Frame Fault: Analog input |
| Fan Alarm | FAN FAULT | Frame Fault: Fan error |
| Input Channel Mute | INPUT MUTE | Input x mute |

Table 6-1: LM 26 Faults (RED FAULT / WARNING LED)

| Warning Description | LCD Warning Text | Event Log Warning Text |
|------------------------|------------------|--------------------------------|
| Digital Clock Slipping | CLOCK SLIPPING | AES/Dante input clock slipping |
| Temperature Warning | TEMP WARNING | Temp Warning: DSP area |
| Controller Offline | CTRL OFFLINE | n/a |

Table 6-2: LM 26 Warnings (YELLOW FAULT / WARNING LED)



Module Input/Output mute status is indicated by the dedicated mute button LEDs. Clipping is indicated by the associated red meter segment. Please refer to section 6.8 for further details.

6.7.3 Rotary Encoder **C**

The rotary encoder is used to adjust parameters in conjunction with the selection made via the dynamic function buttons and LCD menus. The ring around the rotary encoder illuminates when a selected parameter is available for adjustment.

Turn the encoder clockwise to increase the selected parameter, or counter-clockwise to decrease the value. Parameters with only two states (e.g. ON, OFF) are toggled by turning clockwise or counter-clockwise. Some parameters enable simultaneous adjustment of a combination of input and output channels.

To select which channels are adjusted:

1. Press the associated soft button/s to select the parameter/s for editing.
A selected parameter is indicated by inverse text and background color.
2. Use the rotary encoder to change the value.

It is possible to select multiple parameters for simultaneous editing even if the values are different on each channel. Turning the rotary encoder will adjust each parameter by the same increment. When in Meter Mode, the rotary encoder allows the user to change between the available meter views.



Some menus permit parameters to be adjusted across multiple channels simultaneously by default.

6.7.4 Dynamic Function Buttons

The buttons surrounding the display are unlabeled because their functions change according to the currently selected menu or display.

In Menu Mode these buttons are used to navigate the menu structure. A white LED illuminates on each button when a valid menu option is available.

6.8 Module I/O Mute Buttons and LED Meters

The LM 26 provides mute functions at several points in the audio signal path. Please refer to section 5.1 for mute locations and descriptions.

Three types of mute are available from the front panel:

1. LM 26 Input Mutes
2. Module Input Mutes
3. Module Output Mutes

LM 26 Input Mutes are displayed on the LCD screen in Input Meter Mode and are controlled using the adjacent buttons and rotary encoder. The Input Mutes can also be viewed and changed via the front panel I/O CONFIG Menu. Module Input and Output Mutes are controlled via the dedicated mute buttons underneath each channel's five-segment LED meter as shown in Figure 6-4.

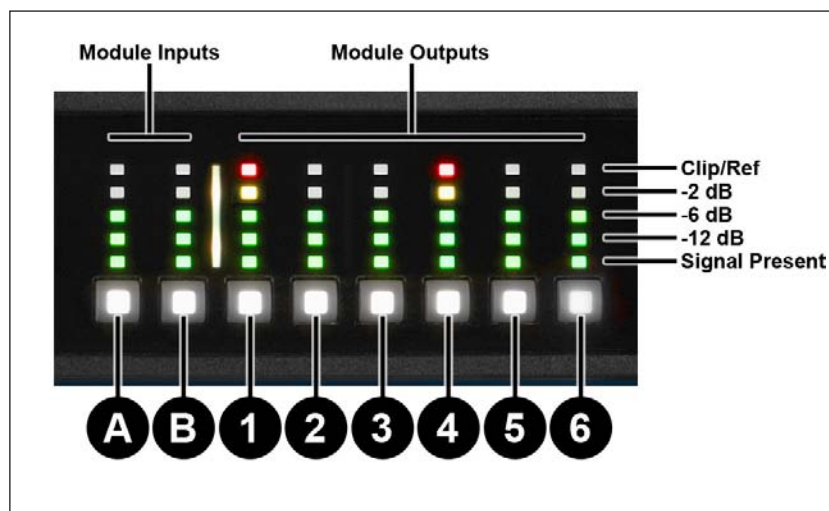

Figure 6-4: LM 26 Dedicated Module Input and Output Mutes

6.8.1 Module Input and Output Mutes

The LM 26 provides dedicated mute buttons for the two module inputs (A/B) and six module outputs (1>6) as labelled in Figure 6-4. To mute or unmute a module input or output, tap the corresponding button. The button is illuminated white when unmuted, and red when muted.

Refer to the Lake Controller Operation Manual for details of Module mute controls via the software.

6.8.2 Clip Indication

The dedicated 5-segment metering LEDs (Figure 6-4) display Module input and output clip or pre-clip conditions. Additionally, the faults and warnings LED described in section provides clip warnings for LM 26 input mutes, or GPIO protective mutes, along with confirmation text on the LCD screen.

Clipping is monitored at the following positions in the signal chain:

- ▶ Analog Inputs: If the input signal exceeds either +12 dBu or +26 dBu (according to analog sensitivity setting), a clip indication will be given. This does not apply if digital inputs are selected.
- ▶ Module Inputs: If the signal level at this point exceeds +25 dBu, a clip indication will be given.
- ▶ Module Outputs: If the signal level at this point exceeds +21 dBu, a clip indication will be given.

6.9 Meter Mode

6.9.1 Home View

The default view when powering on the device is Meter Mode > Home View as shown in Figure 6-5.



Figure 6-5: Meter Mode > Home View

Home View provides a summary of Module I/O gain level and limiter gain reduction, along with frame, module and channel labeling information.

6.9.2 I/O Status View

Pressing the METER button while in Home View results in the I/O Status View being displayed, similar to that shown in Figure 6-6.



Figure 6-6: Meter Mode > I/O Status View

- A** This section displays the screen title (left) and frame fault or warning description (right)
 - B** This section displays confirmation of the following settings:
 - ▶ Dante Clock Master (no icon = Dante Slave or Dante Disabled)
 - ▶ AES Input Terminated (no icon = AES Input Unterminated)
 - ▶ Analog Inputs Grounded (no icon = Analog Inputs Floating)
 - ▶ Analog Outputs Grounded (no icon = Analog Outputs Floating)
 - C** The main section of the I/O Status View displays status and metering information for the four input routers. The information displayed for each input includes the currently selected input source type, input gain level meter (displayed as a horizontal bar and as numeric dB), input mute status, analog headroom, digital sample rate, digital clock selection and digital clock locking status.
- If an LM 26 input is muted, the top-right LED is illuminated red as shown in Figure 6-6, and the frame fault text in section A of the screen will display INPUT MUTE. The fault and warning LED illuminates red or yellow in all Meter and Menu Views as described in section .
- D** These buttons allow muting/unmuting of the associated input. Confirmation of each input's mute status is displayed on the LCD next to the associated button as shown for input 2 in Figure 6-6.
 - E** The faults and warnings LED is accompanied by text on the top-right side of the LCD. The LED illuminates red if any input is muted, or if another fault condition occurs; it illuminates yellow if a warning condition arises. Please refer to section for further details.

6.10 Menu Mode

6.10.1 Overview

The majority of functions can be accessed via Menu Mode on the front panel. These functions include the adjustment of gain, delay, limiters, input and output routing, and the ability to recall Frame Presets. Menu Mode can be accessed at any time by pressing the MENU button.

After pressing the MENU button, various submenu options are displayed as shown in Figure 6-1.



Figure 6-7: Menu Mode > Main Menu

Press the illuminated button adjacent to the required option to display an associated submenu. When parameter level is reached, individual parameters may be selected for adjustment by pressing the adjacent button. The selected parameter value/s are highlighted, and are adjustable using the rotary encoder.

A parameter may be adjusted simultaneously across multiple channels by selecting all values to be adjusted; any current value offsets are retained. Some parameters default to multiple selection, with all inputs or outputs adjusted simultaneously. Changes are effected in real-time and are stored without further confirmation. Pressing EXIT returns to the previous menu level, automatically retaining any parameter changes.



All parameters are editable via the Lake Controller unless specified otherwise.

6.10.1.1 Parameters with Individual Values and Group Totals

The following parameters display two values:

- ▶ MODULE > GAIN
- ▶ MODULE > DELAY
- ▶ MODULE > LIMITERS > MAXRMS LEVEL
- ▶ MODULE > LIMITERS > MAXPEAK LEVEL

The Module parameter can be adjusted using the rotary encoder. The Group total (shown in brackets) is only adjustable using the Groups function in the Lake Controller.

The Group total is the sum of the individual Module value plus any values for this parameter on all Groups to which the Module is assigned. Please refer to the Lake Controller Operation Manual for further information on Groups.

6.10.1.2 Menu Structure Overview

From the Main Menu, the following submenus are available, as shown in Figure 6-7 and described in the following sections.

- ▶ MODULE (See section 6.10.2)
 - ▶ Mixer Gain
 - ▶ Gain
 - ▶ Delay
 - ▶ Polarity
 - ▶ Limiters

- ▶ INPUT CONFIGURATION (See section 6.10.3)
 - ▶ Input Router
 - ▶ AES Termination
 - ▶ Iso-Float
 - ▶ Output Router

- ▶ FRAME (See section 6.10.4)
 - ▶ Frame Information
 - ▶ Frame Reset
 - ▶ Latency Match
 - ▶ GPIO Configuration
 - ▶ Front Panel

- ▶ FRAME PRESETS (See section 6.10.6)
 - ▶ Preset Recall



For simplicity, the following sections refer to the buttons by their associated name on the LCD screen. E.g. 'Press GAIN' equates to 'Press the button adjacent to the Gain label on the LCD'.

6.10.2 Module Submenu

MENU > MODULE

After selecting the Module Menu, the screen shown in Figure 6-8 is displayed. Press the illuminated button adjacent to the required option to view or edit the associated parameters.



Figure 6-8: Module Submenu

6.10.2.1 Mixer Gain

MENU > MODULE > MIXER GAIN



Figure 6-9: Module Input Mixer Gain Edit Screen

The top left button labeled PAGE toggles between the input mixer gain settings for each Module in the Frame. Press any other illuminated button to select a parameter for editing then use the rotary encoder to make adjustments. Multiple parameters may be selected and adjusted together.

6.10.2.2 Gain

MENU > MODULE > GAIN

For frames where both Modules have four output channels or less, a detailed parameter screen as shown in Figure 6-10 is displayed. Where Module A has five output channels or more, the combined summary edit screen shown in Figure 6-11 is the only screen available.



Figure 6-10: Single Module Gain Edit Screen

Pressing the top left PAGE button scrolls between the following three views for modules with four output channels or less:

1. Module A Input and Output Gain Settings (with Group totals)
2. Module B Input and Output Gain Settings (with Group totals)
3. Module A & B Combined Summary (without Group totals)

Pressing any other illuminated button on any of these three screens allows direct editing of the Module parameter using the rotary encoder.



Figure 6-11: Module A+B Combined Gain Summary Edit Screen

On the combined module summary screen, use the NAV button to navigate through the channels, and the SEL button to select a parameter for editing. Selected parameters are highlighted using inverse video on the value. The navigation cursor is identified by a bounding box around the abbreviated channel label. Multiple gain values may be adjusted in 0.1 dB increments subject to defined level limits.

6.10.2.3 Delay

MENU > MODULE > DELAY

Module Delay adjustment follows the same logic as Module Gain. Please refer to the section 6.10.2.2 for further information. Multiple delay values may be adjusted simultaneously in 0.1 ms increments, subject to defined level limits.

The audio signal may be delayed (typically for reasons of driver or delay subsystem alignment) at either the Module inputs or on individual outputs. Delay added at the inputs affects all outputs equally, and will generally be introduced to time-align arrays of loudspeakers at different locations. Delaying individual outputs may be desirable to time-align drivers in the same cabinet or array.

6.10.2.4 Phase (Polarity)

MENU > MODULE > PHASE

Module Phase adjustment follows the same logic as Module Gain. Please refer to the section 6.10.2.2 for further information. Phase may be changed on one input or output at a time.

Audio phase reversal is available at the inputs to Module A and Module B, and also individually on the six output channels. The LCD displays 'Positive' for normal operation, and 'Negative' when the phase is inverted.

6.10.2.5 Limiters

MENU > MODULE > LIMITERS

LimiterMax parameters can be adjusted via this submenu. By default, simultaneous adjustment of most limiter parameters across all output channels is selected, although channels may be adjusted individually if required. Attack and Release times must be adjusted individually per channel.

MaxPeak Level (MaxPeakLvl)

This sets the maximum peak signal level at the Module outputs. It is adjustable from -30 dBu to +30 dBu in 0.1 dB increments, subject to user-defined level limits. The Group total is displayed (in brackets) for each channel.

MaxRMS Level (MaxRMSLvl)

This sets the maximum RMS signal level at the Module outputs. It is adjustable from -30 dBu to +30 dBu in 0.1 dB increments, subject to user-defined level limits. The Group total is displayed (in brackets) for each channel.

MaxRMS Corner (MaxRMSCor)

A soft-knee or hard-knee corner may be applied to the RMS Limiter. A soft-knee corner gently increases limiting as the signal approaches the threshold; a hard-knee corner applies full limiting to any signal exceeding the threshold by any amount, but none to signals below the threshold.

The Corner parameter is adjustable in 0.1 dB increments, subject to defined level limits. This figure represents the level below the limiter threshold at which compression commences; the larger this negative value, the softer the knee. A setting of 0 dB implies a hard-knee characteristic.



LimiterMax provides peak and RMS limiting features, referred to as MaxPeak and MaxRMS respectively. Full details regarding LimiterMax can be found in the Lake Controller Operation Manual.

6.10.3 I/O Config Submenu

MENU > I/O CONFIG



Figure 6-12: I/O Config Submenu

This menu provides configuration options for input and output routing, along with settings for AES Termination and Iso-Float as described in the following sections.

6.10.3.1 Input Router

MENU > I/O CONFIG > INPUT RTR



Figure 6-13: Input Router 1

Figure 5-1 on page 10 shows that there are six Input Routers available on the LM 26. The signal from the first four Input Routers can be routed to the Input Mixer for Module A & B, or directly to any output.

The first four input routers act as a switch, permitting one channel per router to be passed into the input mixers or directly to any output. Similarly, routers 5+6 (pass-thru routers) provide input switching capability, allowing any input to be routed to any output.

Each router has four priority levels allowing any input to be placed in a sequence providing automatic input signal fail over. AES3 and Dante inputs have priority over analog inputs.



Only one analog input is allowed in each router, and the analog input must be at the lowest priority level in relation to any other inputs.

Two modes of input selection are available, Auto Select and Forced Selection. The selected setting is also visible from the I/O STATUS screen on the front panel, and via the Lake Controller.

In Auto Select mode, Priority 1 is checked for a valid input signal; if no signal is found, Priority 2 is checked, and so on until a valid signal is located; this process occurs if the currently selected signal fails. In Forced Selection mode, one of the four priorities is fixed regardless of whether a valid signal is present.

With a router selected on the front panel, press the middle button on the left of the LCD to activate this parameter for editing; the text will be highlighted as shown in Figure 6-13. Use the illuminated rotary encoder to scroll through the following options:

- ▶ Auto Select (default)
- ▶ Force Priority 1
- ▶ Force Priority 2
- ▶ Force Priority 3
- ▶ Force Priority 4

Assignment of Input Priority

Factory default settings assign AES3 to Priority 1 and Analog to Priority 4, with Priority 2 and 3 empty.

To change these settings via the front panel, select Priority slot number to be changed and use the rotary encoder to scroll through the available options. Due to the signal hierarchy it is not possible to assign an analog source to a higher priority than a digital source. Dante inputs are not selectable from the front panel of the LM 26; their assignment must be made via the Lake Controller software.

Analog Input Sensitivity and Digital Gain Offset

While viewing the Input Router screen as shown in Figure 6-13, press PAGE to reveal existing input sensitivity for analog inputs, or digital gain offset for digital inputs. This is equivalent to the DISPLAY DETAILS option in the Lake Controller. Adjust a parameter by pressing the associated button, and then use the rotary encoder to change the value.

The maximum input level accepted by the analog input pre-amplifiers without clipping may be set to 12 dBu or 26 dBu. Digital gain offset may be applied to AES3 digital input signals in 0.1 dB increments from -100 dB to +15 dB.

6.10.3.2 AES3 Input Termination

MENU > I/O CONFIG > AES TERM



Figure 6-14: AES Termination Edit Screen

To adjust the AES3 Input Termination, select AES TERM from the I/O CONFIG menu then use the rotary encoder to toggle the value. A setting of 'Terminated' is also displayed on the I/O STATUS screen.

For fault-free operation when using AES3 digital audio as an input source, inputs must be correctly terminated with the characteristic impedance of 110 ohm. The Input Termination setting is determined by the method used to distribute the AES3 signals.

The processor at the end of a distribution line should be set to TERMINATED; all other processors should be set to UNTERMINATED. If an AES3 distribution amplifier (DA) is being used to distribute the digital audio signals, with one DA output per processor, then all terminations should be on. However, if the AES3 is daisy-chained, only terminate the last processor in the chain.

6.10.3.3 Iso-Float

MENU > I/O CONFIG > ISO-FLOAT

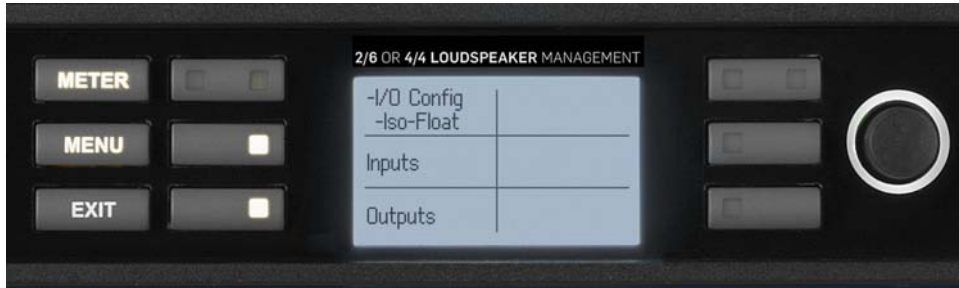

Figure 6-15: Iso-Float Menu

To change the Iso-Float setting, press the Inputs or Outputs button, then adjust the value using the rotary encoder. The current settings are also displayed on the front panel I/O STATUS screen.

The analog inputs utilize Iso-Float transformerless electronic balancing circuitry. This provides electrical isolation from an analog source comparable to that achieved with transformer-based designs. However, pin 1 of the XLR input connector may be connected to ground within the LM 26 if desired. This option is selected by using the rotary encoder to toggle between FLOATING and GROUNDED.

It may be necessary to change this setting to resolve ground loop problems when using analog inputs.

6.10.3.4 Output Router

MENU > I/O CONFIG > OUTPUT RTR

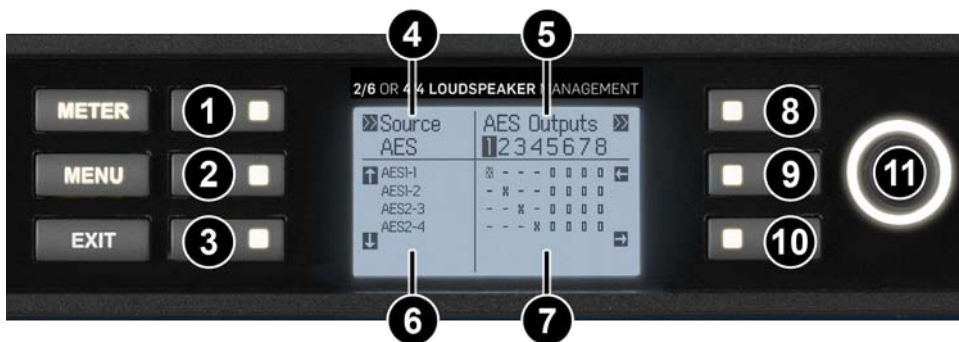

Figure 6-16: Output Router Configuration Screen

The LM 26 provides comprehensive output routing via the front panel interface. Figure 6-16 shows the functions available along with numbers to identify the various features described below.

- 1 Press this button to toggle through the available audio sources

- ② Press this button to move the cursor upwards
- ③ Press this button to move the cursor downwards
- ④ This section of the screen displays the selected audio source
- ⑤ This section of the screen displays the selected output destination type
- ⑥ This section of the screen displays the channels for the selected audio source
- ⑦ This section of the screen displays the output routing configuration
- ⑧ Press this button to scroll through the available output destination types
- ⑨ Press this button to move the cursor to the left
- ⑩ Press this button to move the cursor to the right
- ⑪ Use the rotary encoder to toggle the selected routing point ON or OFF

Use the above function keys to navigate to the required audio source and output destination, then move the cursor to a routing point and adjust using the rotary encoder.

- ▶ 'X' identifies a connected routing point
- ▶ 'O' identifies a currently unused and available routing point
- ▶ '—' identifies that routing is unavailable for this routing point, normally because another audio channel is already routed to the output.

All three states are shown in inverse video when they are selected by the cursor.

6.10.4 Frame Submenu

MENU > FRAME



Figure 6-17: Frame Menu

The Frame Menu provides information and options relating to the LM 26 as a physical unit. It is referred to as a Frame for consistency with Lake Controller terminology.

6.10.4.1 Frame Info

MENU > FRAME > FRAME INFO

Frame Info provides information about the device settings and configuration. All data in this front panel menu is read-only; some parameters are fixed, some can be changed only via the Lake Controller software.

Frame Label

The Frame Label as defined in the Lake Controller is displayed in this menu. It is also displayed at the top-left of the screen in Meter Mode, Home View.

Serial Number (Serial No.)

The printed serial number on the back panel of the LM 26 is also electronically embedded in the hardware, and therefore cannot be removed or altered if stolen.

Network

Pressing the NETWORK button displays a further screen containing network configuration information. All parameters are view-only on the front panel and are either not editable, or can only be adjusted via the Lake Controller.

A summary at the top right of the screen confirms whether a valid connection is present for both Ethernet ports, and whether the Lake Controller is online.

- ▶ IP Addr: Displays the Internet Protocol address for the selected unit and can only be changed via the Lake Controller software. Please refer to the Lake Controller Operation Manual for further details.
- ▶ IP Mask: Displays the IP address subnet mask for the selected unit and can only be changed via the Lake Controller software. Please refer to the Lake Controller Operation Manual for further details.
- ▶ MAC: Displays the unique Media Access Control Ethernet address for the processor. This value cannot be changed.
- ▶ F.ID: Displays the Frame ID, a unique Lake product identifier that cannot be changed.

6.10.4.2 Frame Reset

MENU > FRAME > RESET

Use this option to display a further menu with options to reset all parameters back to their original factory default values. See section 8.3 for a full list of these values. Two types of reset are provided, Factory Reset and Soft Reset.

Factory Reset

A Factory Reset will reset all settings and parameters to the original factory-defined default values. This includes the deletion of any Frame Presets stored within the device. It also resets the IP Address and all network related settings; a hard power cycle is required to complete this reset.

Soft Reset

A Soft Reset will reset all settings and parameters to the original factory-defined default values, but retains Frame Preset information and IP / Network configuration. A power cycle is not required to complete this type of reset.

6.10.4.3 Latency Match

To turn Latency Match on or off, select the parameter using the adjacent button then change the status using the rotary encoder.

When Latency Match is ON the LM 26 adds delay to match the overall processing delay of legacy Lake Contour Pro 26 and Mesa Quad EQ products. Please refer to the Lake Controller Operation Manual for further information.

6.10.4.4 GPIO

MENU > FRAME > GPIO



Figure 6-18: GPIO Menu

Four general purpose input/output configuration settings are available; two configuration options for inputs, and two for outputs.

GPI Configuration

To adjust GPI 1 or GPI 2, press the associated button to display a screen similar to that shown in Figure 6-19.



Figure 6-19: GPI Configuration

Table 6-3 lists the options available for General Purpose Input (GPI). These options can be set independently for a transition from closed > open and from open > closed.

| Acting on | Transition Option |
|-----------------------|---|
| Protective Mute State | 1. No Action 2. Toggle State 3. Mute 4. Unmute |
| Standby State | 1. No Action 2. Toggle State 3. Standby 4. Turn On |
| Preset Recall | 1. No Action 2. Recall #99 3. Recall #100 |
| No Action | - |

Table 6-3: GPI Options

A change to the 'Acting on' setting takes effect the next time the transition occurs. For example, changing a GPI closed to open transition when the selected GPI is currently open is not executed until the next transition to open.



A change in GPI open/closed state occurring when the LM 26 is disconnected from power will be acknowledged and executed when power is reconnected.

GPO Configuration

To adjust GPO 1 or GPO 2, press the associated button to display a screen similar to that shown in Figure 6-20



Figure 6-20: GPO Configuration

Table 6-4 lists the options available for General Purpose Output (GPO).

| Acting on | State when Closed |
|-----------------------|-----------------------------|
| Protective Mute State | 1. Muted 2. Unmuted |
| Standby State | 1. Standby 2. On |
| Fault | 1. No Fault 2. Any Fault |
| Ready | 1. Ready 2. Not Ready |
| No Indication | - |

Table 6-4: GPO Options



Factory Reset and Soft Reset clear the protective mute state.

Two input options (GPI) and two output options (GPO) may be set at any one time. The default GPIO configuration is shown in Table 6-5. The current state (open/closed) is reported for all GPIO settings on the LM 26 front panel and in the Lake Controller software.

| GPIO # | Default Option |
|--------|----------------|
| GPI 1 | No Action |
| GPI 2 | No Action |
| GPO 1 | Standby State |
| GPO 2 | Fault |

Table 6-5: Default GPIO Configuration

6.10.5 Front Panel Display Controls

MENU > FRAME > FRONT



Figure 6-21: Front Panel Display Controls Menu

Contrast

To adjust the front panel LCD contrast, select this option then use the rotary encoder to change the value.

Dimming

To adjust the front panel LCD brightness, select this option then use the rotary encoder to change the value.

6.10.6 Frame Preset Menu

MENU > FRAME PRST



Figure 6-22: Frame Preset Menu

To recall an existing Frame Preset, use the rotary encoder to select the required Preset then press the RECALL button to overwrite the current configuration.



Frame Presets must initially be created in the Lake Controller, and stored as a Preset using the Lake Controller or Lake Preset Manager.

Up to 100 Frame Presets can be stored in the device. The data within a Frame Preset includes the configuration of all Modules in the Frame including levels, crossovers, EQ, input mixer, and output routing.

As Frame Presets are stored within the device, complete processor configurations can be recalled without connecting the device to a PC.

7. Back Panel Interface

An overview of the back panel interface is provided in section 4.2. This chapter describes each cluster of connections as shown in Figure 7-1.

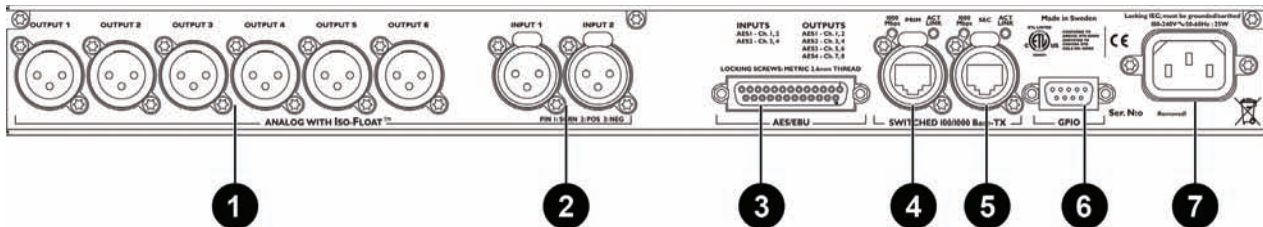

Figure 7-1: Back Panel Interface

7.1 Analog Inputs and Outputs

7.1.1 Analog Output XLR Connections ①

Six electronically-balanced analog outputs are provided via standard XLR3M connections.

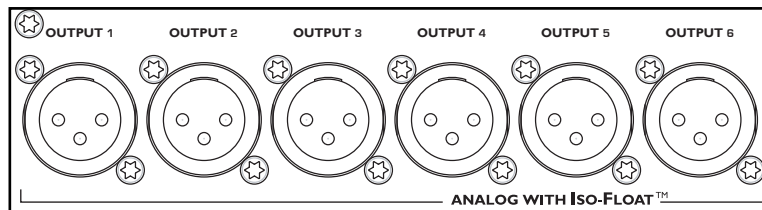

Figure 7-2: Analog Output XLR Connections

7.1.2 Analog Input XLR Connections ②

Two electronically-balanced analog inputs are provided via latching XLR3F connections.

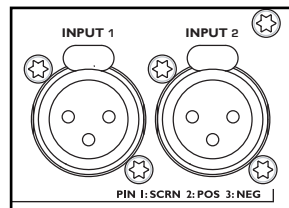

Figure 7-3: Analog Input XLR Connections

7.1.3 Analog XLR Wiring and Pin Out

All XLR connections are wired to IEC268 as shown in Figure 7-4.

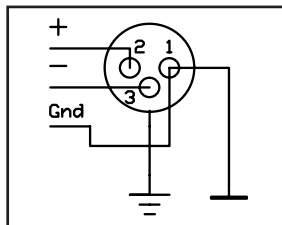

Figure 7-4: IEC268 XLR Wiring and Pin Out

- Pin 1: Ground / Shield
- Pin 2: Hot (+)
- Pin 3: Cold (-)

7.1.4 Unbalanced Operation

Balanced connections are recommended where possible. However, if it is necessary to drive the device from equipment with an unbalanced output, wire the inputs as shown in Figure 7-5.

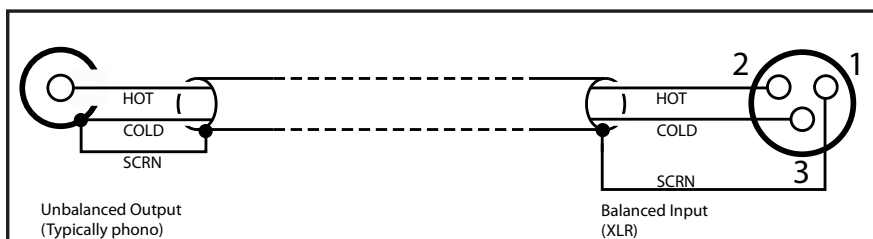

Figure 7-5: Balanced to Unbalanced Analog Wiring and Pin Out

The method shown in Figure 7-5 uses twin-and-screen (balanced) cable and standard XLR pin connections at the LM 26 end, with the cold wire and the cable screen connected to the signal ground of the equipment at the source end.

This usually provides better noise and hum rejection than the more common method of joining pins 1 and 3 together in the XLR. However, if only a single-core (unbalanced) cable is available, the method shown in Figure 7-6 may be used.

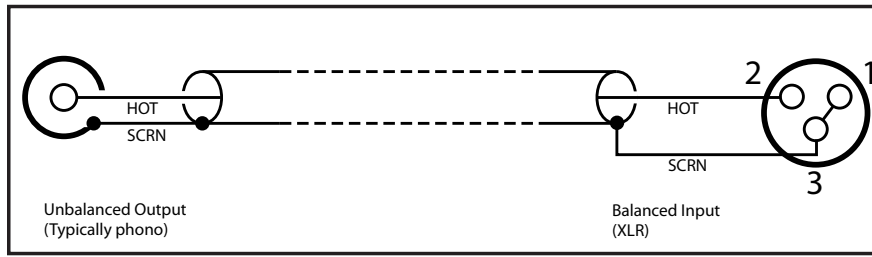

Figure 7-6: Unbalanced Analog Wiring and Pin Out

7.1.5 Iso-Float Electronic Balancing

The analog input and output electronic balancing circuits use the Lake Iso-Float system.

The Iso-Float technology combines the benefits of transformer-coupled isolation with the advantages of clean, direct-coupled inputs and outputs. The audio converters are galvanically isolated, and not connected to the main ground. High-quality transformers and opto-isolators create a barrier between the device and possible grounding aberrations from the outside electrical environment.

Iso-Float settings are adjustable via the front panel menu or the Lake Controller software.

7.2 AES3 Digital I/O

7.2.1 AES3 DB25 Connector ③

A DB25 connector, following the Yamaha pin-out standard, is provided for AES3 connectivity on the LM 26.

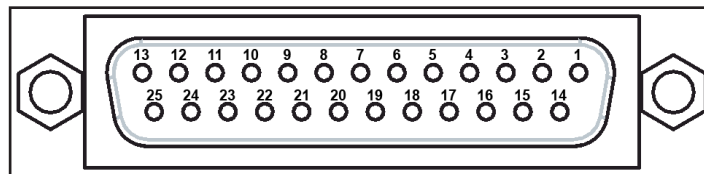

Figure 7-7: AES3 DB25 Connector and Pinout Reference

This single DB25 connection provides four channels of AES3 input and eight channels of AES3 output as shown in Figure 7-4 on page 39 below. A detailed wiring reference is provided in Figure 7-8.

| AES3 Inputs | AES3 Outputs |
|-----------------|-----------------|
| AES1: Ch. 1 & 2 | AES1: Ch. 1 & 2 |
| AES2: Ch. 3 & 4 | AES2: Ch. 3 & 4 |
| | AES3: Ch. 5 & 6 |
| | AES4: Ch. 7 & 8 |

Table 7-1: DB25 Input and Outputs

Figure 7-8 below provides a wiring reference for the DB25 connector.

| Ch. | Ground | Hot | Cold |
|---------|--------|-----|------|
| 1/2 IN | 10 | 1 | 14 |
| 3/4 IN | 10 | 2 | 15 |
| 5/6 IN | 12 | 3 | 16 |
| 7/8 IN | 13 | 4 | 17 |
| 1/2 OUT | 22 | 5 | 18 |
| 3/4 OUT | 23 | 6 | 19 |
| 5/6 OUT | 24 | 7 | 20 |
| 7/8 OUT | 25 | 8 | 21 |

Figure 7-8: DB25 Wiring Reference

Figure 7-4 on page 39 shows the only possible method of wiring; there is no equivalent of an unbalanced connection in the digital domain.

7.3 RJ45 etherCON® Network Connections

Two RJ45 etherCON style network connections are provided as shown in Figure 7-9.

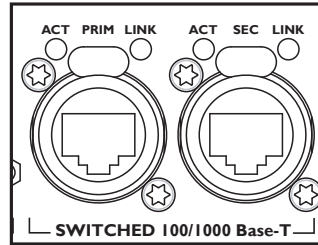

Figure 7-9: etherCON Network Connectors

The network connections auto-sense whether standard or crossover Cat-5e cables are in use. Pre-made cables with moulded RJ45 plugs are recommended. If it is necessary to make up custom Cat-5e network cables, use pinout described in Table 7-2.

| Pin No. | Color |
|---------|----------------|
| 1 | Brown |
| 2 | Brown + White |
| 3 | Green |
| 4 | Blue + White |
| 5 | Blue |
| 6 | Green + White |
| 7 | Orange |
| 8 | Orange + White |

Table 7-2: RJ45 Wiring & Pin Out Description

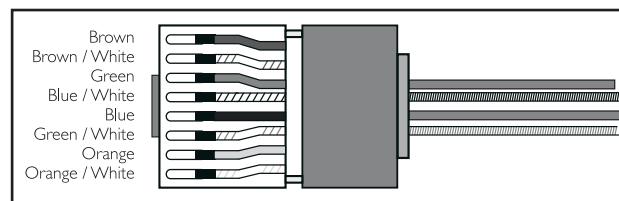

Figure 7-10: RJ45 Wiring and Pin Out Diagram

When the device is connected to an active network, the yellow LINK LED illuminates above the connector in use. Data activity on the network is indicated by illumination of the green ACT LED. It is normal for the ACT LED to flicker either sporadically or continuously.

7.3.1 Primary Network Connection ④

The Primary Network connection is used for Lake Controller connectivity and Dante digital audio. Please refer to section 4.2 for additional information.

7.3.2 Secondary Network Connection ⑤

The Secondary Network connection may be used for a redundant Dante digital audio network. Please refer to section 4.2 for additional information.

7.4 GPIO Connection

7.4.1 9-Pin GPIO Connector ⑥

A General Purpose Input/Output (GPIO) connection is provided, allowing interface to external devices such as fire alarm systems for emergency muting, processor power control, or preset recall. The GPO function allows fault and state monitoring via external systems. Figure 7-11 in conjunction with Table 7-3 describes the pinout configuration for the GPIO connector.

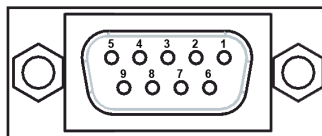

Figure 7-11: 9-Pin GPIO Connector and Pinout Reference

| Pin No. | Description |
|---------|----------------|
| 1 | GPI 1a |
| 2 | GPI 1b |
| 3 | GPI 2a |
| 4 | GPI 2b |
| 5 | Chassis Ground |
| 6 | GPO 1a |
| 7 | GPO 1b |
| 8 | GPO 2a |
| 9 | GPO 2b |

Table 7-3: GPIO Pinout Wiring Reference

GPIO configuration is available via the LM 26 front panel interface or via the Lake Controller software. Please refer to section 6.10.4.4 of this manual for additional information on adjustment via the front panel, and refer to the Lake Controller Operation Manual for information on adjusting via software interface.

7.5 Universal Power Supply Connection

7.5.1 IEC Power Connector ⑦

A universal power supply capable of accepting 70-265 V ~ 50-60 Hz : 30 W is built into the LM 26. The IEC power cable provided includes a locking feature via a pin on the bottom of the connector; the connector can accept standard or locking IEC power cables.

The power supply must be connected to AC mains using an IEC power cable with a correctly wired and molded plug for the country of operation.

8. Appendix

8.1 Faults and Warnings Overview

Fault or warning conditions are indicated by the LED shown in Figure 6-3 on page 16. As the LED indicates several types of faults or warnings, a brief textual description of the fault or warning is provided on the LCD display. Section on page 19 details the fault and warning indications that appear on the front panel. Table 8-1 lists the events that may have triggered each fault or warning condition.

| LCD Text | Event Log Text | Type | Description / Troubleshooting |
|-----------------|---------------------------|---------|--|
| ANALOG IN FAULT | Frame Fault: Analog Input | Fault | There is a problem with the analog input. Verify signal and connections. |
| CLOCK SLIPPING | AES Clock Slipping | Warning | The selected digital clock and digital input combination is not aligned. Verify digital input configuration to ensure all clock settings match. |
| CTRL OFFLINE | - | Warning | The LM 26 is no longer able to communicate with the Lake Controller. Check network connectivity. |
| FAN FAULT | Frame Fault: Fan error | Fault | There is a problem with the fan on the LM 26. To avoid overheating, identify and fix the problem immediately. |
| INPUT MUTE | Input X Mute | Mute | An input is muted; all Modules and outputs sourced from this input will be affected. |
| NO INPUT | No Input Source | Fault | No input signal of any type can be identified. Connect an input source, or verify input signals and connections. |
| OVERTEMP | Temp Fault: DSP area | Fault | The temperature has reached a critical 70°C (158°F). Turn the unit off or take steps to cool the unit immediately; continued operation cannot be guaranteed. |
| PROTECTIVE MUTE | Protective mute via GPIO | Event | A processor mute state has been triggered via GPIO. Change this setting using the external control device. |
| TEMP WARNING | Temp Warning: DSP area | Warning | The temperature has reached 55°C (131°F). Monitor the temperature and take additional steps to reduce temperature if it continues to increase. |
| - | Frame Offline | Warning | The Lake Controller is no longer able to communicate with the LM 26. Check network connectivity. |
| - | Module Input Mute | Mute | A Module Input has been muted. The mute is identified via the associated Module Input mute button on the front panel. |
| - | Module Output Mute | Mute | A Module Output has been muted. The mute is identified via the associated Module Output mute button on the front panel. |
| - | Sound Source Changed | Warning | The input source has been changed either manually or by automatic input priority detection. |

Table 8-1: Warning, Fault and Mute Indications (alphabetical by LCD Text / Event Log Text)

8.2 Maintenance

During normal operation this device provides trouble-free service. If the LCD or front panel display requires cleaning, use a soft cloth only; do not use solvent cleaners. The dust filter on the right-hand side air intake should occasionally be removed and cleaned to ensure maximum airflow through the device.



Disconnect the unit from mains power prior to removing dust the filter, and ensure the dust filter is replace prior to turning the unit back on.



Do not use sharp or metal objects to remove the dust filter, and be careful that the implement used to remove the filter does not enter the device.

In extreme cases it may be necessary to clean the inside of the device. This procedure should only be carried out by qualified service personnel. This may be necessary if the device has had prolonged operation in an extreme environment such as one where cracked oil smoke machines are in use. If the device is used in extreme conditions, it is recommended to have it serviced every three years as a preventative measure.

8.3 Factory Default Settings

8.3.1 Module Defaults

| | |
|--------------------|---------------------|
| Module Type: | 2 x Classic 3-Way |
| Mod Input Mute: | On |
| Mod Output Mutes: | Off |
| Gain: | 0 dB (unity) |
| Delay: | 0 ms |
| Polarity: | Positive (In phase) |
| MaxRMS: | 20 dB |
| MaxPeak: | 21 dB |
| Input & Output EQ: | Flat |

8.3.2 Input and Router Defaults

| | |
|--------------------|---|
| Autoselect: | On |
| Input sensitivity: | +26 dBu |
| Dante: | Disabled |
| AES3: | Terminated |
| Iso-Float: | Enabled |
| Router 1: | AES1 (Ch.1) as Priority 1, Analog 1 as Priority 4 |
| Router 2: | AES1 (Ch.2) as Priority 1, Analog 2 as Priority 4 |
| Router 3: | AES2 (Ch.3) as Priority 1, Analog 1 as Priority 4 |
| Router 4: | AES2 (Ch.4) as Priority 1, Analog 2 as Priority 4 |
| Router 5: | AES1 (Ch.1) as Priority 1, Analog 1 as Priority 4 |
| Router 6: | AES2 (Ch.1) as Priority 1, Analog 2 as Priority 4 |

8.4 Glossary of Terms, Acronyms and Abbreviations

The explanations given in Table 8-2 below are based on the specific use of each term in this manual. The definitions are not intended to be exhaustive and many of these terms have wider meanings.

| Term | Description |
|----------------------------------|---|
| 100/1000 Base-T | 100/1000 Base-T is IT industry-speak for different standards of Ethernet network. This term incorporates 100 Base-TX, which operates at 100 Mbps, and 1000 Base-T which operates at 1000 Mbps (1 Gbps). |
| Access Point | See Wireless Access Point. |
| Auto-Sensing | The Ethernet ports automatically determine the base speed of the network they are connected to (10 Base-T or 100 Base-T) and configure themselves appropriately. This is termed auto-sensing. |
| Auto-Uplink | The Ethernet ports can operate with either straight or crossed network cables. This ability to connect correctly with either type is termed auto-uplinking. |
| Auxiliary Output | Some of the configurations possible in the Lake processing system Modules result in a single audio processing channel being created in addition to a crossover. This is termed an Auxiliary output. |
| Backbone | Large Ethernet networks are often implemented with a very high speed "trunk" part of the network topology feeding main switches, which in turn support smaller, lower-speed local networks. The term backbone is used to describe such a trunk. |
| Bandwidth | The bandwidth of a signal channel or interconnection is the range of frequencies it is able to handle. The term can be applied to both audio channels and Ethernet networks. |
| Cat-5e/Cat-6, etc. | Designations of industry-standard cables suitable for Ethernet networks using four twisted pairs of conductors. Often referred to as UTP cable (Unscreened Twisted Pair). Cat-5 has generally been replaced by Cat-5e (e = 'enhanced'). Either Cat-5e or Cat-6 cable are suitable for networking Lake and Lab.gruppen devices. |
| Chain | An Ethernet network comprising several devices interconnected using the Secondary connectors to daisy-chain the units together is an example of a network with a chain topology. |
| Clock | Digital audio is produced by sampling analog audio at a known, fixed rate, controlled by some form of master clock. Problems can occur when interconnecting two pieces of digital audio equipment if their internal master clocks are not synchronized. Various techniques may be employed to ensure that this is the case. |
| CPL | Relevant only to PLM Series devices. Short for Current Peak Limiter, a Lab.gruppen protection technique which ensures that the amplifier's output transistors can never attempt to deliver more than their rated current. |
| Crossed Network Cable | An Ethernet cable in which four of the eight conductors (pins 1, 2, 5 & 6) are not wired pin-to-pin. Such a cable is required in conventional IT networks to connect two PCs together without using a hub or switch. The auto-uplink feature of the Ethernet ports allows crossed cables to be used if wished. See also Straight network cable. |
| Dante | A new-generation audio data protocol developed by Audinate® Pty Ltd, allowing multichannel high-resolution digital audio plus control data to be transmitted via standard IT-industry networks using TCP/IP data packets. The Lake processing system integrated within the LM 26 includes a dual-redundant Dante network interface, providing digital audio inputs and outputs via Ethernet. |
| dBu | dBu's are usually used instead of voltages to describe signal levels in audio systems. A signal level of 0 dBu may be taken as 0,775 Vrms. |
| Delay | Up to two seconds of delay may be added to the input and/or output channels to time-align loudspeaker arrays. |
| Digital Gain Offset | Digital gain offset is effectively a 'fine' gain adjustment performed in the digital domain, which can be applied to digital input signals to optimize the signal to the gain structure. |
| Distribution Amplifier | A distribution amplifier (usually abbreviated to DA) is an audio buffer stage – usually with zero gain – with one input and several outputs. Mono, stereo and AES3 digital versions can be obtained. Use of a DA to feed a signal to several destinations ensures correct impedance matching and isolation between source and destinations. |
| Dual-Network Topology | A network topology consisting of two (usually) identical networks, one connecting to the Primary Ethernet ports and the other to the Secondary ports. Although more complex to implement, the advantage of using a dual-network system is one of greatly improved reliability as one complete network remains operational if the other should fail. |
| Electronic Balancing | See Balancing. In the analog domain, balanced inputs and outputs may be provided on audio equipment either by the use of transformers (traditional, very good, but heavy and expensive) or via electronic balancing circuits (nearly as good, without full electrical isolation, but a great deal cheaper). |
| Event Log | The details of any fault or warning conditions which arise in the device during operation are recorded in a data file created by the Lake Controller software called the Event Log. |
| Fault | A Fault in the device occurs when one of the operating parameters exceeds pre-determined safety levels, or when a condition is detected that otherwise seriously affects the performance. Some fault conditions may result in one or all of the channels being muted. |
| Fingerprint | Relevant only to PLM Series devices. The Lake Controller comes includes a LoadLibrary consisting of data describing the electrical characteristics of commonly-used loudspeakers. The file for each speaker type is termed its Fingerprint. |
| Finite Impulse Response (filter) | An alternative design of crossover filter realisable in the digital domain, providing linear phase characteristics. FIR filtering is provided in all Lake devices. |
| Floating | An analog balanced input or output is said to be floating when full electrical isolation exists between that input or output and the equipment connected to it. Transformer-coupled inputs and outputs are inherently floating. Electronically balanced inputs and outputs can never be truly floating, though better designs – such as that found in the LM 26 – do mimic the characteristics of transformer-coupled designs to a high degree. |
| Frame | Lake terminology for a physical unit containing a Lake processing system, i.e. a single LM 26, PLM or legacy Lake Processor. |

| Term | Description |
|------------------------|--|
| Frame ID | An electronic identification 'label' which can be given to each Frame in an amplification system. Naming Frames in a large system is desirable as it simplifies identification in the Lake Controller. |
| Frame Preset | Frame Presets are a class of Presets within the Lake processing system. Up to 100 can be stored in the hardware device, and each holds the complete configuration of all Modules and the Modules' internal settings. |
| Hub | A type of network interface device with multiple Ethernet ports. Data arriving at any port is sent to all others. Hubs have been largely replaced by Switches. |
| In-Rush Current | Relevant only to PLM Series devices. When power is applied to a piece of electronic equipment, the initial current taken by the PSU can be very high as the various capacitors in the circuitry charge up; this is called the in-rush current. In the case of power amplifiers, which contain numerous very large capacitors, the in-rush current can be enough to blow mains breakers. The PLM's PSU contains circuitry to control the in-rush current to prevent this. |
| Input Level | The amplitude of an audio signal at the point where it is applied to the input of the device, or at the input of an intermediate stage within it. An analog input signal level will be expressed in dBu's, while a digital input signal level in dBFS (dBs below digital clip level; fS = full-scale) |
| IP Address | Every item of equipment connected to an Ethernet network has a unique address called the IP address, so that data gets to the correct place. IP addresses are written as four groups of three decimal numbers between 0 and 255. In a system consisting of Lake Processors and a Lake Controller they are assigned and detected automatically. |
| IP Subnet Mask | IP subnet masks are required in all IP networks. The subnet is determined by the size and type of network being used. For small networks (less than 254 addresses) a subnet mask of 255.255.255.0 can be used. (A Class C network). |
| Iso-Float | Iso-Float is Lake's proprietary method of electronic balancing, which provides a particularly high level of isolation and immunity from ground loops. |
| ISVPL | Relevant only to PLM Series devices. ISVPL is an abbreviation for Inter-Sample Voltage Peak Limiter, a proprietary Lab.gruppen technique for ensuring that voltage at the output terminals of a PLM does not exceed a pre-determined level. |
| Lake Controller | The Lake Controller is the software application used to control LM 26 Processors, PLM Series and other Lake devices. This software application provides additional functionality and allows various grouping functions for simultaneous control of multiple Lake Processing-enabled devices. |
| Latency | The small but finite delay incurred by audio signals when they are transformed into the digital domain, processed digitally and then converted back into analog signals. In the Lake system, latency is assured to be constant. |
| Legacy Lake Device | This term refers to older Lake audio equipment which may form part of an audio system (i.e. Lake Contour Pro 26, Lake Mesa Quad EQ and the Dolby Lake Processor). The Lake Controller has the capability to control all Lake legacy products. |
| LimiterMax | LimiterMax is the name given to Lake's proprietary package of dynamics control which forms part of the Lake Processing system. |
| Line Driver | An analog audio amplifier, usually with zero gain, having very low output impedance and high drive capability. They are used for transmitting balanced analog audio over very long cables. |
| Linear Phase Crossover | See FIR Filters |
| Load Library | Relevant only to PLM Series devices. The Lake Controller includes LoadLibrary, a set of Module files specific to the PLM Series. These Modules include a database of the electrical characteristics of various popular loudspeakers in addition to the standard Module data. The PLM uses the load data when verifying and monitoring amplifier loads. See Fingerprint, LoadSmart and SpeakerSafe. |
| Load, equal/unequal | Relevant only to PLM Series devices. The PLM draws different current levels from the AC supply, and thus has different power ratings according to whether all channels of the amplifier are driving into the same load impedance, or if there are different impedances on different channels. |
| LoadSmart | Relevant only to PLM Series devices. LoadSmart is a load verification procedure within the PLM which allows the operator to confirm that each PLM output has the correct quantity and type of speaker connected to it. It is intended to be used pre-performance prior to running SpeakerSafe. |
| Loop-Thru | Relevant only to PLM Series devices. This term refers to the Link connectors provided on the PLM for daisy-chaining further amplifiers or other equipment. The use of these to connect further devices is termed a loop-thru. |
| MAC Address | In addition to an IP address, every device on an Ethernet network has a MAC address. This address is fixed at the time of manufacture, and is effectively the permanent identifier of the physical unit. MAC stands for Media Access Control |
| MaxPeak | Lake's LimiterMax provides independent dynamics control over signal peaks (MaxPeak) and the average signal level (MaxRMS). |
| MaxRMS | See MaxPeak. |
| Module | Module is the term used in the Lake Controller to describe the virtual set of signal processing that routes an audio input to the various frequency-weighted outputs of a crossover. The processing system within the device allows for two Modules, each of which may be assigned a range of crossover configurations, input sources, etc. |
| Module Preset | A class of Preset within the Lake processing system. A Module Preset (Module file) contains all the configuration data and settings for one Module, and is saved in the Lake Controller software, not in the hardware device. |
| Offline | A device on an Ethernet network which is not communicating with the rest of the network either due to a fault or intentionally is said to be offline. |
| Online | A device on an Ethernet network which is fully operational and communicating with the rest of the network is said to be online. |
| PAL | Relevant only to PLM Series devices. Short for Power Average Limiter, PAL is proprietary Lab.gruppen circuit which provides additional amplifier protection. The PAL ensures that the power drawn by the PSU from the AC mains does not exceed the mains breaker ratings. |
| Parallel | Two or more e.g. inputs which are wired together so that all inputs are connected to the same source are said to be paralleled. Signal levels will be reduced if too many inputs are paralleled; in the case of AES3, this may result in a complete loss of audio. |
| Parameter | Any control function which can be adjusted by the user to one of several different values is termed a parameter. For example, input level, gain, delay, and limiter threshold are all parameters. |

| Term | Description |
|--------------------------|--|
| Pass-Through Cable | See Straight network cable. |
| Ping | Ping is a term coined by the IT industry to the procedure of sending a command over a network to a particular Ethernet device asking it to confirm its identity and possibly reply with additional information. Thus an Lake device on the network can be pinged from the Lake Controller; on receipt of the 'ping', the hi-intensity white LED on the front panel illuminates. Reverse pinging is also possible, whereby the ping is instigated from Lake hardware device and a visual identification of the processor registers in the Lake Controller software. |
| Preset | A complete frame configuration that is stored in the device hardware. |
| Primary Ethernet Port | The Primary Ethernet port on the is the means of connecting the device to a network. See also Secondary Ethernet Port. |
| PSU | Abbreviation of Power Supply Unit. The PSU in any item of electronic equipment converts the AC mains into a set of internal DC voltages which run the electronic assemblies themselves. |
| RJ45 | RJ45 connections are the industry-standard connectors for Ethernet ports. |
| Router | As far as networks of the type discussed in this manual are concerned, see Switch. |
| Secondary Ethernet Port | The Secondary Ethernet port can be used either as a daisy-chain output, repeating the network connection at the Primary port, or for the connection of a separate second network for full redundancy. |
| Short Circuit Protection | Relevant only to PLM Series devices. A Lab.gruppen proprietary protective circuit designed to mute a channel when a short circuit is detected at its output terminals to prevent damage to the device. |
| Soft Function Buttons | The eight buttons around the front panel display are called soft function buttons because their function varies depending upon which display page is currently on-screen. |
| SpeakerSafe | Relevant only to PLM Series devices. Once activated, SpeakerSafe constantly monitors the voltage and current at the PLM's outputs. Using Fingerprint data, the software then calculates parameters such as voice coil and magnet temperatures, providing the operator with real-time performance monitoring. See LoadLibrary. |
| Speakon | Relevant only to PLM Series devices. An industrial-quality loudspeaker connector manufactured by Neutrik. 4-pole (2 speakers) and 8-pole (4 speakers) versions are fitted to various versions of the PLM. |
| Star Topology | A network topology which uses a network switch to connect to individual Lake devices. Each device connects to one port on the switch with its own cable, thus the network looks like a star when drawn as a diagram with the switch at the centre. |
| Straight Network Cable | A Cat-5/6 network cable with full pin-to-pin connections is called a straight network cable. Lake devices can connect to a network using either straight or crossed network cables. |
| Subsystem | It is possible when working with large networked systems to store selected components of the system into a Subsystem. This is useful if working on a tour that encompasses both large and mid-sized venues. The same core Lake Controller data can then be used for a reduced number of Lake devices. |
| Super Module | A Super Module is a virtual construct that can be realized within the Lake Controller, allowing a set of Modules in different Frames to be treated as a single Module. |
| Switch (Ethernet) | An Ethernet switch allows several Ethernet devices to be connected to a network using a star topology. More intelligent than the earlier hubs which they now largely replace, they route packets of data only to the units for which they are intended, and also perform other system housekeeping and control functions. |
| System Preset | A class of Preset within the Lake Processing system, System Presets allow Module or Frame configurations and settings to be stored for the entire network of LM 26 Processors, PLM Series and other legacy Lake devices. |
| Tablet PC | A compact PC which uses a touchscreen instead of keyboard and mouse. The Lake Controller has been optimized for use on Tablet PCs. |
| Termination | AES3 digital audio interconnections must be correctly terminated for reliable operation. The 110 ohm terminations must be set 'on' at the beginning and end of a set of daisy-chained digital audio equipment, and 'off' at any intermediate ones. |
| Topology | A mathematical word for "arrangement" or "configuration". The topology of a network is a means of visualizing the overall configuration of the network. |
| VHF Protection | VHF protection is another amplifier safety circuit developed by Lab.gruppen. The presence of continuous HF audio can easily damage loudspeakers, so the protection circuit monitors the output this, muting the power output channel if necessary |
| View | The information available in the front panel display's Meter mode is split into three pages which are termed Views. |
| V peak | Relevant only to PLM Series devices. Indicates the peak voltage of an audio signal. For a sinusoidal signal, the peak voltage = 1.414 x the RMS voltage, Vrms. Not to be confused with peak-to-peak voltage (written V pk-pk), which = V peak x 2. |
| Vrms | The RMS voltage of a signal. See RMS. |
| Wireless Access Point | A device used to connect a computer to an Ethernet network without cables; a radio transmitter/receiver for data. |
| Wireless Network | An Ethernet network where some or all cabled connections are replaced by wireless links. |

Table 8-2: Glossary of Terms, Acronyms and Abbreviations

9. Application Guide

This chapter describes the practical application and use of the LM 26.

9.1 Gain Structure

The LM 26 architecture provides gain adjustments at various points in the signal path and therefore, various places for muting and level adjustment. Each mute or gain adjustment point serves a different purpose. The signal flow diagram in chapter 5 provides a useful reference for the signal path. The following sections describe the various adjustment points, all of which are available via the Lake Controller software.

9.1.1 Input Headroom (Analog Inputs Only)

This parameter should be set relevant to the output level of the analog audio source (e.g. mixing console). This setting does not affect the other gain stages, or the overall noise floor; it allows control of the appropriate headroom at the input stage only.

To adjust, navigate to I/O CONFIG > INPUT CONFIGURATION in the Lake Controller. Please refer to the Lake Controller Operation Manual for further details.

9.1.2 Input Mixer

Input Mixer gains can remain at 0.00 dB for most configurations; if only one input channel is used per Module, the other can be set to -INF.

To adjust, navigate to I/O CONFIG and tap the Input Mixer blocks for the Module in the Lake Controller. Please refer to the Lake Controller Operation Manual for further details.

9.1.3 Module Input Gain

Input Gain is used to adjust the level between different speaker cabinets in the system. This gain can remain at 0.00 dB unless a lower level is required for the cabinet/s driven by this Module.

To adjust, navigate to MODULES > EQ/LEVELS > LEVELS in the Lake Controller. Please refer to the Lake Controller Operation Manual for further details.

9.1.4 Module Output Gain (Levels)

Factory and User Gain are provided for each Module output. These two stages provide a level of security and control for the system designer (Factory) and a further level of adjustment for the user (User), both of which combine to balance the level between frequency bands in a multi-way crossover.

1. Factory Gain is set by the system designer and can be hidden within the Module file. The Factory Gain parameter is only accessible when the Module is unlocked and the Lake Controller is in Designer Mode. Adjust via MODULES > LEVELS > METER OPTIONS > ADJUST FACTORY.
2. User Gain is editable by a user unless the system designer has locked away the parameter; adjust via MODULES > LEVELS.

Generally, output gain values are configured within a Module / loudspeaker preset file and should not need to be adjusted further.

9.2 Gain / Level Optimization

9.2.1 Maximize Volume Capability

To maximize the volume capability of the device, ensure there is sufficient headroom in the signal path to avoid clipping before the limiters engage. It must be possible to achieve enough gain through the device to engage the limiters and realize a high average SPL. As an optimal setting, allow for a headroom of 10 dB or more for all channels; the simplest way to accomplish this is to increase the Module input gain.

9.2.2 Minimize Noise

To help provide the best volume to noise ratio, use an AES or Dante digital input signal wherever possible. If using analog inputs, ensure that unused or unnecessarily high headroom is not introduced at the input to the device. If full or high average power is not required, the Module input gain may be reduced.

9.3 Digital Audio Connections

Whenever possible, it is preferable to connect a digital rather than analog input signal to the device. This is particularly relevant if the source signal is already in the digital domain, such as the source from a digital mixing console or digital distribution system. The primary cause of signal distortion and signal delay (latency) is the digital-to-analog and analog-to-digital conversion process. Therefore, using digital inputs normally provides higher quality audio with lower latency.

Two types of digital audio inputs are available: Dante networked multi-channel digital audio, and two-channel digital audio via the AES3. Dante-based system configurations and interconnections are explained in a separate document, the Lake Network Configuration Guide.

The information in this section is supplied for users unfamiliar with AES3. Users already familiar with AES3 will find that the device conforms to established conventions.

9.3.1 AES3 Digital Audio

The original AES/EBU digital audio interface standard was developed by the Audio Engineering Society in conjunction with the European Broadcast Union. Originally published in 1985, it was revised in 1992 and 2003, and in its current iteration it is properly designated the AES3 standard.

AES3 is a serial transmission format for linearly represented (uncompressed) digital audio data. It describes a method for carrying two channels of periodically sampled and uniformly quantized audio signals on a single twisted-pair cable.

The data format allows for auxiliary data which can be used for information on signal characteristics as well as the sampled audio data. The physical interconnection, as defined by IEC 60958 Type I, specifies three-conductor 110-ohm twisted pair cabling terminated by an XLR connector. Please refer to section 7.1.1 for wiring details.

AES3 provides for multiple sampling rates and resolutions of up to 24 bits; this device accepts sample rates from 44.1 to 192 kHz.

9.3.2 System Latency and Delay Compensation

All types of digital audio processing inherently involves a small processing delay referred to as latency. If the processing chain does not involve analog-to-digital or digital-to-analog conversion, the amount of latency is usually very small and often may be disregarded.

However, in complex systems involving multiple digital audio components and connections, enough delay may be generated to cause audio phasing problems. Therefore, the lowest latency is always preferred, and it is always important to consider system latency delays when calculating and adjusting overall delay for time-aligning multiple loudspeaker systems.

9.3.3 External Signal Distribution Hardware

9.3.3.1 Distribution Amplifiers

Dedicated distribution amplifiers for AES3 signals are available from several manufacturers. The most common format is one input and six outputs. Digital distribution amplifiers are designed to refresh or reconstruct the signal as well making up for line losses.

One type of distribution amplifier is a simple repeater, which restores the waveform shape and brings the signal amplitude back up the required level. Some distribution amplifiers also offer a re-clocking feature, which also re-times the signal to prevent signal degradation from clocking errors known as jitter.

Distribution amplifiers that offer re-clocking often make the feature optional as using re-clocking can introduce small additional amounts of latency, so should not be used unless necessary.

9.3.3.2 Passive splitters

In some limited applications, a single AES3 input may be split into two signals using a simple passive splitter. Splitters provide a convenient and low cost solution when only one additional signal is required, and in situations where cable lengths are short. Attenuation is minimal, but there is no refreshing of the signal.

9.3.4 Additional Reference Material

Complete technical information on the AES/EBU (AES3) standard can be downloaded from the AES web site at <http://www.aes.org/publications/standards/>.

9.4 Digital Clock Configuration

9.4.1 Digital Clock Overview

In order to provide a flexible and robust audio processing system, the LM 26 is equipped with a configurable digital clocking system. There are two separate digital clocks which can generate various independent internal sample rates, or can sync to an incoming AES3 signal. Figure 9-1 shows the various sample rates and options available.

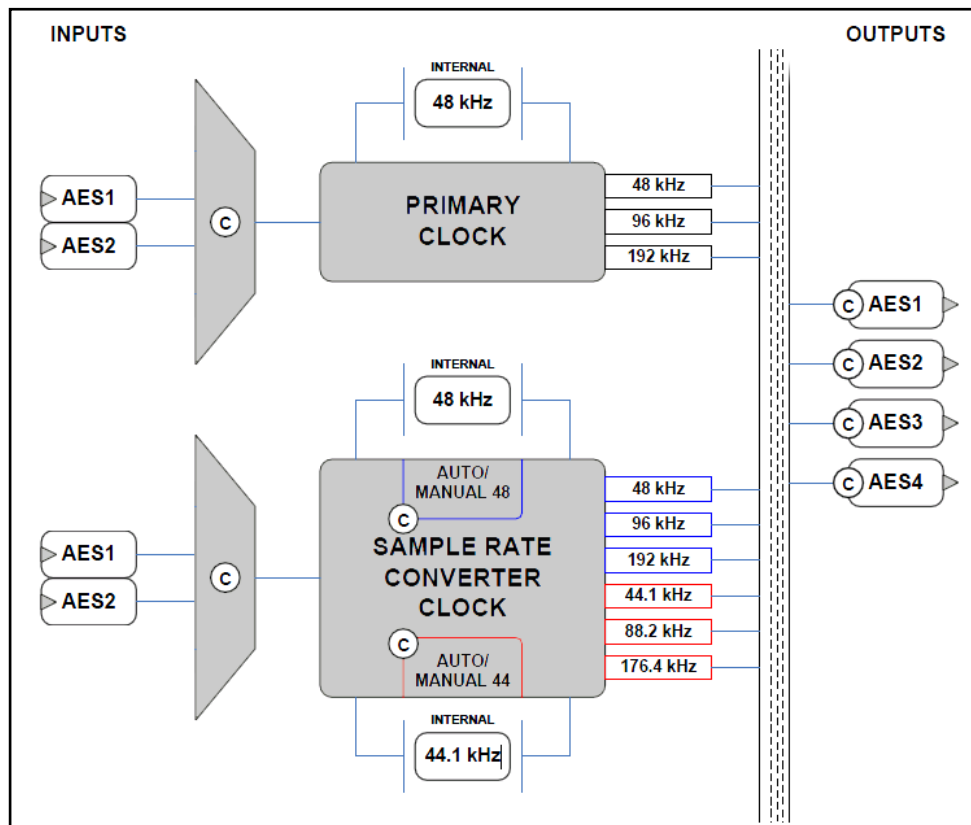

Figure 9-1: Digital Clocking System

In Figure 9-1, each circled C represents a choice point. A choice point is a user-interface control that can be configured using the Lake Controller software. Please refer to the Lake Controller Operation Manual for further information.



Figure 9-1 indicates internally generated clocks with base-rate multiples of 44.1 kHz or 48 kHz. This should not be confused with the internal DSP sample rate of 96 kHz.

Both the Primary and Sample Rate Converter (SRC) clocks can either generate their own internal clock signal, or synchronize to an incoming AES3 signal. An incoming AES3 signal can be locked using automatic clock detection or manual clock selection.

The Primary and SRC clocks produce multiple audio clocks derived from a base sample rate. The Primary Clock's base rate is 48 kHz, which also derives the 96 and 192 kHz clocks. The SRC Clock's base rate can be either 44.1 or 48 kHz. If the SRC Clock's base rate is 44.1 kHz, then 88.2 and 176.4 kHz clocks are also derived; if the SRC Clock's base rate is 48 kHz, then 96 and 192 kHz clocks are also derived.

In most typical applications, SRC Clock will be set at a base rate of 44.1 kHz. A base rate of 48 kHz is provided to allow for both synchronous (via Primary Clock) and asynchronous (via SRC Clock) I/O.

All clocks derived from the Primary and SRC clocks are available to drive the AES3 audio outputs. The desired sample rate can be selected independently for each AES3 output pair, as shown on the right side of Figure 9-1.

For example, you could configure AES1, AES2, and AES3 to provide 96 kHz AES3 outputs to drive digital amplifiers in the sound system, and configure AES4 to provide a 44.1 kHz audio recording output for media or broadcast purposes.

9.4.2 Clock Source Priorities

There are two options for clock source configuration: Manual Configuration or Automatic Detection.

For Manual Configuration, the selected internal or external clock source remains fixed regardless of whether a compatible clock signal is preset.

For Automatic Detection, the most appropriate clock matching the selected base-rate is automatically selected according to the following priorities.

1. AES1 (Input 1+2)
2. AES2 (Input 3+4)
3. Internal Clock

When using automatic detection, the AES3 digital input is monitored and will switch the clock source back and forth depending on the availability of an AES3 signal.

Please refer to the Lake Controller Operation Manual for additional information.

9.4.3 Dante Clock Configuration

Dante uses its own digital clocking technology across the Ethernet network to ensure that all Dante devices are synchronized. As part of this logic, an order of priority is defined to identify which device becomes the Dante Master. A Dante-capable device with a valid BNC Word Clock is chosen as the highest priority, followed by a device with a valid AES3 signal, then SPDIF, then an internally generated clock.

Dante only operates at 48 kHz or 96 kHz, and therefore only uses the Primary Digital Clock to lock the sample rate for the Dante Master. The Primary Clock on all Dante Slaves will be overridden by the Dante Clock.

The front panel I/O Status View indicates if that device is selected as Dante Clock Master. Confirmation of Dante Master / Slave status is also displayed in the Lake Controller.



For further information on Digital Clock configuration and the Lake Controller user interface, please refer to the Lake Controller Operation Manual.

9.4.4 Signal Processing Latency

The information in Table 9-1 lists the total latency for common input-output configurations.

| Input Configuration | Output Configuration | Total Latency (ms) |
|---------------------|----------------------|--------------------|
| Analog | Analog | 1.036 |
| 48 kHz sync | Analog | 1.207 |
| 96 kHz sync | Analog | 0.951 |
| 48 kHz async | Analog | 1.215 |
| 96 kHz async | Analog | 1.182 |
| 44.1 kHz async | Analog | 1.214 |
| 88.2 kHz sync | Analog | 1.181 |
| 96 kHz sync | 96 kHz sync | 0.872 |
| 44.1 kHz async | 44.1 kHz async | 1.363 |
| 88.2 kHz async | 88.2 kHz async | 1.345 |
| 48 kHz async | 48 kHz async | 1.356 |

Table 9-1: Latency for Common Input-Output Configurations

10. Technical Specifications

2-in/6-out Digital Audio Loudspeaker Processor

2 Contour Modules

Raised Cosine Mesa and Ideal graphic input equalizer

Linear phase and classic crossovers and output EQ

LimiterMax peak and RMS limiter

Delay, mute, phase, gain

Audio Performance

| | |
|---|-----------------------|
| Internal sample rate | 96 kHz |
| A/D and D/A conversion resolution | 24 bit |
| Internal data path | 32 bit floating point |
| Product propagation delay, best case (96 kHz AES to 96 kHz AES) | 0.872 ms |
| Product propagation delay, analog (Analog in to Analog out) | 1.036 ms |
| Maximum available delay | 2 seconds |

Analog

| | |
|---------------------------------------|--|
| Inputs and Outputs | 2 inputs, 6 outputs |
| Dynamic range, inputs | 116 dB |
| Dynamic range, outputs | 115 dB |
| Frequency response, analog to digital | +/-0.1 dB, 20 Hz to 20 kHz |
| Frequency response, digital to analog | +/-0.03 dB, 20 Hz to 20 kHz |
| THD + Noise, inputs | 0.00024% at 1 kHz |
| THD + Noise, outputs | 0.00037% at 1 kHz |
| Iso-Float ground isolation | Yes, separate setting for input and output |
| Input sensitivity settings | 12 or 26 dBu |
| Maximum output level | 21 dBu |
| Input impedance | 20 kOhm balanced, 10 kOhm unbalanced |
| Common Mode Rejection (CMR) | >74 dB, 20 Hz to 20 kHz |
| Crosstalk | -98 dB, 20 Hz to 20 kHz |

AES3

| | |
|------------------------|------------------------------------|
| Inputs and Outputs | 4 inputs, 8 outputs |
| Supported resolutions | Up to 24 bit |
| Supported sample rates | 44.1, 48, 88.2, 96, 176.4, 192 kHz |
| Termination | Selectable |

Dante Audio Network

| | |
|--------------------------|---------------------|
| Inputs and Outputs | 4 inputs, 8 outputs |
| Supported sample rates | 48, 96 kHz |
| Supports redundant paths | Yes |
| Flexible topology | Yes |
| Network latency | 0.5, 0.8, 1.3, 4 ms |

Front panel user interface

| | |
|----------------------------------|--|
| Display | Daylight readable monochrome |
| Meters | LED meters and clip indicators per channel |
| Mute access | Mute button and LED indication per channel |
| LED Fault and Warning indication | Yes |
| Parameter adjustment | Rotary encoder |
| Standby Power button | On/Standby |

Back panel interface

| | |
|----------------------------------|---|
| Analog inputs and outputs | 2 + 6 XLR |
| AES inputs and outputs | DB-25 |
| Ethernet | Dual Neutrik etherCON |
| GPIO | DB-9 |
| Power | Locking 3-pin IEC |
| Control and monitoring interface | Via Ethernet for Lake Controller software |

Ethernet

| | |
|------------------|-------------|
| Gigabit Ethernet | 1000 Base-T |
| Fast Ethernet | 100 Base-Tx |

GPIO

| | |
|---|--|
| Inputs | 2 General Purpose Inputs (GPI) supporting external contact closure |
| Outputs | 2 General Purpose Outputs (GPO) with internal contact closure |
| Software configurable input control | Standby state, Mute state, Dual Preset recall |
| Software configurable output indication | Standby state, Mute state, Faults, Ready |

Device presets

| | |
|---------------|-----|
| Frame presets | 100 |
|---------------|-----|

Power

| | |
|-------------------|--------------|
| Nominal voltage | 100-240 V |
| Operating voltage | 70-265 V |
| Power consumption | 30 W maximum |

Dimensions

W: 483 mm (19"), H: 44 mm (1 U), Overall D: 290 mm (11.5")

Weight 5 kg (11 lbs.)

Finish Black painted steel chassis with aluminum handles

Approvals

CE, ANSI/UL 60065 (ETL), CSA C22.2 NO. 60065, FCC

Specifications subject to change without notice

11. Warranty and Support

11.1 General

This product is manufactured by Lake, and it is warranted to be free from any defects caused by components or factory workmanship, under normal use and service, for a period of three (3) years from date of purchase from an authorized Lake dealer.

If the product fails to perform as specified during the warranty period, Lake will undertake to repair, or at its option, replace this product at no charge to its owner, provided the unit is returned undamaged, shipping prepaid, to an authorized service facility or to the factory.

This warranty shall be null and void if the product is subjected to: repair work or alteration by a person other than those authorized by us; mechanical damage including shipping accidents; war, civil insurrection, misuse, abuse, operation with incorrect AC voltage; incorrect connections or accessories; operation with faulty associated equipment; or exposure to inclement weather conditions. Damage due to normal wear and tear is not covered by the warranty. Units on which the serial number has been removed or defaced will not be eligible for warranty service.

Lake shall not be responsible for any incidental or consequential damages. Lake's responsibility is limited to the product itself. Lake takes no responsibility for any loss due to cancellation of any events, or rent of replacement equipment or costs due to a third party's or customer's loss of profit, or any other indirect cost or losses however incurred.

Lake reserves the right to make changes or improvements in design or manufacturing without assuming any obligation to change or improve products previously manufactured.

This warranty is exclusive, and no other warranty is expressed or implied. This warranty does not affect the customer's statutory rights.

11.2 International Warranties

Please contact your supplier or distributor for this information, as rights and disclaimers may vary from country to country.

11.3 Technical Assistance and Service

11.3.1 International Service

If your Lake product requires repair, contact your Lake dealer or distributor, or contact Lake by fax or email to obtain the location of the nearest authorized service centre.

11.3.2 Factory Service

In the event a Lake product requires factory service, you may contact Lake's service department for return instructions and a Return Authorization number.

Please note for product return:

1. Use the original packing.
2. Include a copy of the sales receipt, your name, return address, phone and fax number, email address and description of the defect.
3. Mark the Return Authorization number on the outside of the packing.
4. Ship the product prepaid to:

Lake
Faktorvägen 1
SE-434 37 Kungsbacka
SWEDEN

Phone: +46 300 56 28 00

Fax: +46 300 56 28 99

service@lakeprocessing.com

www.lakeprocessing.com

11.4 Trademarks

Lake is a national and/or international registered trademark of Lab.gruppen AB. PLM, Powered Loudspeaker Management and LM 26, are trademarks of Lab.gruppen AB.

Dolby is a registered trademark of Dolby Laboratories. Raised Cosine Equalization, LimiterMax and Iso-Float are trademarks of Dolby Laboratories. Audinate is a registered trademark of Audinate Pty Ltd. Dante and Zen are trademarks of Audinate Pty Ltd.

All other trademarks remain the property of their respective owners.

Copyright © 2010 Lab.gruppen AB. All rights reserved.



INTERNATIONAL CONTACT ▶ INFO@LAKEPROCESSING.COM US & CANADA CONTACT ▶ INFO@TCG-AMERICAS.COM
WWW.LAKEPROCESSING.COM

LAKE IS A WHOLLY-OWNED SUBSIDIARY OF LAB.GRUPPEN AB, SWEDEN
WWW.LABGRUPPEN.COM